

Corrigenda for 2023 Classification Technical Rules



* Please note that this corrigenda is for the printed version of the 2023 Classification Technical Rules, and the PDF files posted on the website have been corrected.

PART 1

Present	Amendments	Reason
<p style="text-align: center;">CHAPTER 2 PERIODICAL AND OTHER SURVEYS</p> <p style="text-align: center;">Section 2 Annual Survey</p> <p>201. Due range <omitted></p> <p>202. Hull, equipment and fire-extinguishing appliances</p> <p>1. The survey is to consist of an examination for the purpose of ensuring, as far as practicable, that the hull, hatch covers, hatch coamings, closing appliances, <u>and equipment are maintained</u> in a satisfactory condition.</p> <p><hereinafter, omitted></p> <p>Ref.</p> <p>3.2 Scope</p> <p>3.2.1 The survey is to consist of an examination for the purpose of ensuring, as far as practicable, that the hull, hatch covers, hatch coamings, closing appliances, <u>equipment and related piping</u> are maintained in a satisfactory condition. (UR Z7, 3.2.1, Rev.29 May 2022)</p>	<p style="text-align: center;">CHAPTER 2 PERIODICAL AND OTHER SURVEYS</p> <p style="text-align: center;">Section 2 Annual Survey</p> <p>201. Due range <same as the current Rules></p> <p>202. Hull, equipment and fire-extinguishing appliances</p> <p>1. The survey is to consist of an examination for the purpose of ensuring, as far as practicable, that the hull, hatch covers, hatch coamings, closing appliances, and equipment <u>and related piping</u> are maintained in a satisfactory condition.</p> <p><hereinafter, same as the current Rules></p>	<p>- Typo, reflected UR Z7 3.2.1 (English only)</p>

Present	Amendments	Reason
<p data-bbox="103 284 969 347">Annex 1-12 Hull Survey for Classification Survey during Construction</p> <p data-bbox="405 376 667 408">Appendix 1-12-2</p> <p data-bbox="118 440 954 531">Requirements for Tankers and Bulk Carriers subject to SOLAS Ch II-1 Pt A-1 Reg.3-10(Goal-based ship construction standards for bulk carriers and oil tankers)</p> <p data-bbox="118 571 394 603">2. Design Transparency</p> <p data-bbox="154 616 981 978">2.1 For ships subject to compliance with IMO Res. MSC.287(87)(Adoption of the international goal-based ship construction standards for bulk carriers and oil tankers), IMO Res. MSC. 290(87) (Adoption of amendments to the international convention for the safety of life at sea, 1974, as amended), IMO Res. <u>MSC.296(87)</u> (Adoption of the guidelines for verification of conformity with goal-based ship construction standards for bulk carriers and oil tankers) and IMO MSC.1/Circ. 1343(Guidelines for the information to be included in a ship construction file), readily available documentation is to include the main goal-based parameters and all relevant design parameters that may limit the operation of the ship.</p>	<p data-bbox="1014 284 1881 347">Annex 1-12 Hull Survey for Classification Survey during Construction</p> <p data-bbox="1317 376 1579 408">Appendix 1-12-2</p> <p data-bbox="1030 440 1865 531">Requirements for Tankers and Bulk Carriers subject to SOLAS Ch II-1 Pt A-1 Reg.3-10(Goal-based ship construction standards for bulk carriers and oil tankers)</p> <p data-bbox="1030 571 1305 603">2. Design Transparency</p> <p data-bbox="1066 616 1892 978">2.1 For ships subject to compliance with IMO Res. MSC.287(87)(Adoption of the international goal-based ship construction standards for bulk carriers and oil tankers), IMO Res. MSC. 290(87) (Adoption of amendments to the international convention for the safety of life at sea, 1974, as amended), IMO Res. MSC.296(87) <u>MSC.454(100)</u> (Adoption of the <u>Revised</u> guidelines for verification of conformity with goal-based ship construction standards for bulk carriers and oil tankers) and IMO MSC.1/Circ. 1343(Guidelines for the information to be included in a ship construction file), readily available documentation is to include the main goal-based parameters and all relevant design parameters that may limit the operation of the ship.</p>	<p data-bbox="1917 284 2101 435">- Reflection to IACS UR Z23 (Rev.7 Corr. 2 May 2023)</p>

Present	Amendments	Reason
<p style="text-align: center;"><Rule Pt 1></p> <p style="text-align: center;">CHAPTER 2 GENERAL</p> <p>Section 15 Hull Surveys for General Dry Cargo Ships</p> <p>1501. General</p> <p>2. Definitions (1) Refer to the Definitions of Ch 2, Sec 1, <u>101.</u> (2020)</p> <p>3. Procedures for thickness measurements (1) Follow the procedure for thickness measurement of Ch 2, Sec 1. <u>110.</u> (2018)</p> <p>Section 16 Hull Surveys for Liquefied Gas Carriers</p> <p>1601. General</p> <p>2. Definitions (1) Refer to the Definitions of Ch 2, Sec 1, <u>101.</u> (2020)</p> <p>3. Procedures for thickness measurements (1) Follow the procedure for thickness measurement of Ch 2, Sec 1. <u>110.</u> (2018)</p> <p style="text-align: center;">CH 3 HULL SURVEYS OF SHIPS SUBJECT TO THE ENHANCED SURVEY PROGRAMME</p> <p style="text-align: center;">Section 1 General</p> <p>101. Application</p> <p>2. Procedural requirements for certain ESP surveys (4) The following surveys may be witnessed by a single Surveyor: – Thickness measurements in accordance with Ch 2, <u>109.</u> of the Rules</p>	<p style="text-align: center;"><Rule Pt 1></p> <p style="text-align: center;">CHAPTER 2 GENERAL</p> <p>Section 15 Hull Surveys for General Dry Cargo Ships</p> <p>1501. General</p> <p>2. Definitions (1) Refer to the Definitions of Ch 2, Sec 1, <u>102.</u> (2020)</p> <p>3. Procedures for thickness measurements (1) Follow the procedure for thickness measurement of Ch 2, Sec 1. <u>111.</u> (2018)</p> <p>Section 16 Hull Surveys for Liquefied Gas Carriers</p> <p>1601. General</p> <p>2. Definitions (1) Refer to the Definitions of Ch 2, Sec 1, <u>102.</u> (2020)</p> <p>3. Procedures for thickness measurements (1) Follow the procedure for thickness measurement of Ch 2, Sec 1. <u>111.</u> (2018)</p> <p style="text-align: center;">CH 3 HULL SURVEYS OF SHIPS SUBJECT TO THE ENHANCED SURVEY PROGRAMME</p> <p style="text-align: center;">Section 1 General</p> <p>101. Application</p> <p>2. Procedural requirements for certain ESP surveys (4) The following surveys may be witnessed by a single Surveyor: – Thickness measurements in accordance with Ch 2, <u>111.</u> of the Rules</p>	<p>– Typo</p>

Present	Amendments	Reason
<p>102. Preparations for survey</p> <p>7. Survey planning meeting</p> <p>(1) Follow the procedure of Survey planning meeting of Ch 2, Sec 1, <u>109.</u> (2018)</p> <p>104. Procedures for thickness measurements (2021)</p> <p>1. General (2018)</p> <p>(1) Follow the procedure for thickness measurement of Ch 2, Sec 1 <u>110.</u> (2018)</p> <p>3. Reporting (2018)</p> <p>(1) Follow the procedure for thickness measurement of Ch 2, Sec 1 <u>110.</u></p> <p style="text-align: center;">Section 2 Bulk Carriers</p> <p>201. General</p> <p>2. Definitions</p> <p>(1) Refer to the Definitions of Ch 2, Sec 1, <u>101.</u> (2020)</p> <p style="text-align: center;">Section 3 Oil Tankers</p> <p>301. General</p> <p>2. Definitions</p> <p>(1) Refer to the Definitions of Ch 2, Sec 1, <u>101.</u> (2020)</p>	<p>102. Preparations for survey</p> <p>7. Survey planning meeting</p> <p>(1) Follow the procedure of Survey planning meeting of Ch 2, Sec 1, <u>110.</u> (2018)</p> <p>104. Procedures for thickness measurements (2021)</p> <p>1. General (2018)</p> <p>(1) Follow the procedure for thickness measurement of Ch 2, Sec 1 <u>111.</u> (2018)</p> <p>3. Reporting (2018)</p> <p>(1) Follow the procedure for thickness measurement of Ch 2, Sec 1 <u>111.</u></p> <p style="text-align: center;">Section 2 Bulk Carriers</p> <p>201. General</p> <p>2. Definitions</p> <p>(1) Refer to the Definitions of Ch 2, Sec 1, <u>102.</u> (2020)</p> <p style="text-align: center;">Section 3 Oil Tankers</p> <p>301. General</p> <p>2. Definitions</p> <p>(1) Refer to the Definitions of Ch 2, Sec 1, <u>102.</u> (2020)</p>	<p>- Typo</p>

Present	Amendments	Reason
<p style="text-align: center;">Section 4 Chemical Tankers</p> <p>401. General</p> <p>2. Definitions (1) Refer to the Definitions of Ch 2, Sec 1, <u>101</u>. (2020)</p> <p style="text-align: center;">Section 5 Double Hull Oil Tankers</p> <p>501. General</p> <p>2. Definitions (1) Refer to the Definitions of Ch 2, Sec 1, <u>101</u>. (2020)</p> <p style="text-align: center;">Section 6 Double Skin Bulk Carriers</p> <p>601. General</p> <p>2. Definitions (1) Refer to the Definitions of Ch 2, Sec 1, <u>101</u>. (2020)</p>	<p style="text-align: center;">Section 4 Chemical Tankers</p> <p>401. General</p> <p>2. Definitions (1) Refer to the Definitions of Ch 2, Sec 1, <u>102</u>. (2020)</p> <p style="text-align: center;">Section 5 Double Hull Oil Tankers</p> <p>501. General</p> <p>2. Definitions (1) Refer to the Definitions of Ch 2, Sec 1, <u>102</u>. (2020)</p> <p style="text-align: center;">Section 6 Double Skin Bulk Carriers</p> <p>601. General</p> <p>2. Definitions (1) Refer to the Definitions of Ch 2, Sec 1, <u>102</u>. (2020)</p>	<p>- Typo</p>

Present	Amendments	Reason
<p style="text-align: center; color: blue;"><Rule Pt 1></p> <p style="text-align: center;">CHAPTER 1 CLASSIFICATION</p> <p style="text-align: center;">Section 9 Suspension/Withdrawal of Class and Reclassification</p> <p>901. Suspension/Reinstatement of class <omitted></p> <p>902. Withdrawal of class 【See Guidance】</p> <p>1. The classification may be withdrawn under the approval of the Classification Committee.</p> <p>(1) ~ (4) <omitted></p> <p>(5) when the Surveyor reports that the vessel has not complied with the Rules of the Society as regards surveys to maintain the classification specified in Ch 2, 102.</p> <p><hereinafter, omitted></p>	<p style="text-align: center; color: blue;"><Rule Pt 1></p> <p style="text-align: center;">CHAPTER 1 CLASSIFICATION</p> <p style="text-align: center;">Section 9 Suspension/Withdrawal of Class and Reclassification</p> <p>901. Suspension/Reinstatement of class <same as the current Rules></p> <p>902. Withdrawal of class 【See Guidance】</p> <p>1. The classification may be withdrawn under the approval of the Classification Committee.</p> <p>(1) ~ (4) <same as the current Rules></p> <p>(5) when the Surveyor reports that the vessel has not complied with the Rules of the Society as regards surveys to maintain the classification specified in Ch 2, <u>103</u>, 102.</p> <p><hereinafter, same as the current Rules></p>	<p>- Typo</p>

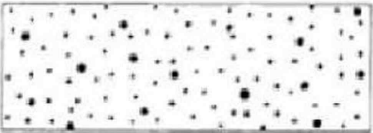
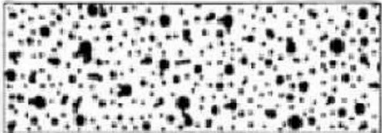
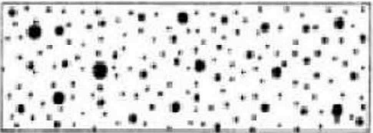
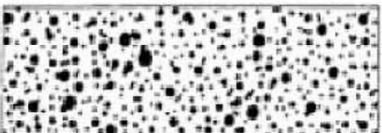
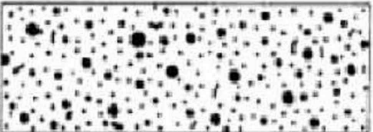
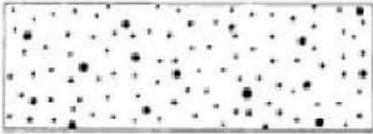
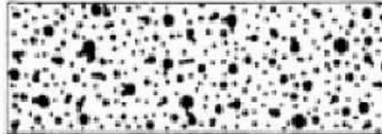
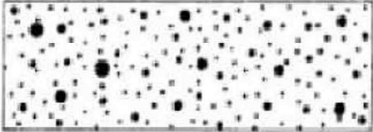
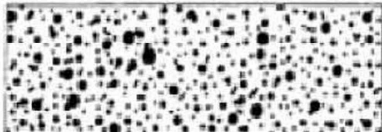
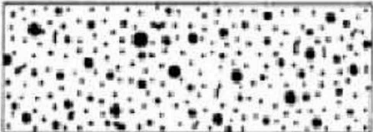
Present	Amendments	Reason
<p style="text-align: center;"><Rule Pt 1></p> <p style="text-align: center;">CHAPTER 2 PERIODICAL AND OTHER SURVEYS</p> <p style="text-align: center;">Section 1 General</p> <p>102. Definitions</p> <p>28. Pitting corrosion is defined as scattered corrosion spots/areas with local material reductions which are greater than the general corrosion in the surrounding area. Pitting intensity is defined in Fig 1.2.3. (2020)</p> <div style="display: flex; justify-content: space-around;"> <div style="text-align: center;"> <p>5% SCATTERED</p>  </div> <div style="text-align: center;"> <p>20% SCATTERED</p>  </div> </div> <div style="display: flex; justify-content: space-around;"> <div style="text-align: center;"> <p>10% SCATTERED</p>  </div> <div style="text-align: center;"> <p>25% SCATTERED</p>  </div> </div> <div style="text-align: center;"> <p>15% SCATTERED</p>  </div> <p style="text-align: center;">Fig 1.2.1 Pitting intensity diagrams</p>	<p style="text-align: center;"><Rule Pt 1></p> <p style="text-align: center;">CHAPTER 2 PERIODICAL AND OTHER SURVEYS HAPTER 2 PERIODICAL AND OTHER SURVEYS</p> <p style="text-align: center;">Section 1 General</p> <p>102. Definitions</p> <p>28. Pitting corrosion is defined as scattered corrosion spots/areas with local material reductions which are greater than the general corrosion in the surrounding area. Pitting intensity is defined in Fig 1.2.3. (2020)</p> <div style="display: flex; justify-content: space-around;"> <div style="text-align: center;"> <p>5% SCATTERED</p>  </div> <div style="text-align: center;"> <p>20% SCATTERED</p>  </div> </div> <div style="display: flex; justify-content: space-around;"> <div style="text-align: center;"> <p>10% SCATTERED</p>  </div> <div style="text-align: center;"> <p>25% SCATTERED</p>  </div> </div> <div style="text-align: center;"> <p>15% SCATTERED</p>  </div> <p style="text-align: center;">Fig 1.2.1 1.2.3 Pitting intensity diagrams</p>	<p>- Typo</p>

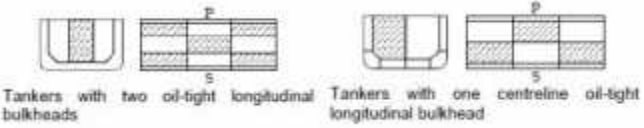
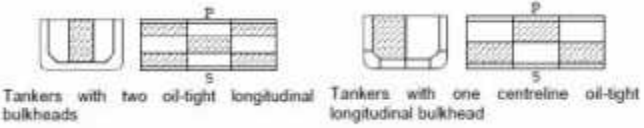
Present	Amendments	Reason
<p style="text-align: center;"><Guidance Pt 1></p> <p style="text-align: center;">Annex 1-16 Procedures for Testing Tanks and Tight CHAPTER 3 HULL SURVEYS OF SHIPS SUBJECT TO THE ENHANCED SURVEY PROGRAMME</p> <p style="text-align: center;">Section 3 Oil Tankers</p> <p>304. Special Survey (2021)</p> <p>1. In application to 304. 5 of the Rules, the following guidance on pressure testing of boundaries of cargo tanks under direction of the master is to be applied. 【See Rule】</p> <p>(4) Pressure testing using cargo</p> <p>(A) In order to test the relevant boundaries, the ship may be loaded in a checker board pattern(Fig 1), so that each cargo tank internal bulkhead is subjected to a fully loaded head of pressure provided that the intended loading and stability condition are checked and confirmed by the master.</p> <div style="text-align: center;">  <p>Tankers with two oil-tight longitudinal bulkheads Tankers with one centreline oil-tight longitudinal bulkhead</p> </div> <p style="text-align: center;">Fig 1 "Stagger test" – checker board pattern</p>	<p style="text-align: center;"><Guidance Pt 1></p> <p style="text-align: center;">Annex 1-16 Procedures for Testing Tanks and Tight CHAPTER 3 HULL SURVEYS OF SHIPS SUBJECT TO THE ENHANCED SURVEY PROGRAMME</p> <p style="text-align: center;">Section 3 Oil Tankers</p> <p>304. Special Survey (2021)</p> <p>1. In application to 304. 5 of the Rules, the following guidance on pressure testing of boundaries of cargo tanks under direction of the master is to be applied. 【See Rule】</p> <p>(4) Pressure testing using cargo</p> <p>(A) In order to test the relevant boundaries, the ship may be loaded in a checker board pattern(Fig † 1.3.1), so that each cargo tank internal bulkhead is subjected to a fully loaded head of pressure provided that the intended loading and stability condition are checked and confirmed by the master.</p> <div style="text-align: center;">  <p>Tankers with two oil-tight longitudinal bulkheads Tankers with one centreline oil-tight longitudinal bulkhead</p> </div> <p style="text-align: center;">Fig † 1.3.1 "Stagger test" – checker board pattern</p>	<p>- Number system changes</p>

Present	Amendments	Reason
<p data-bbox="129 276 943 339">Annex 1-16 Procedures for Testing Tanks and Tight Boundaries (2018)</p> <p data-bbox="360 368 707 400">PART A - SOLAS Ships</p> <p data-bbox="120 411 277 435">2. Application</p> <p data-bbox="154 469 981 528">(3) The testing of structures not listed in Table 3.1.1 or 3.1.2 is to be specially considered.</p> <p data-bbox="120 560 479 584">3. Tests Types and Definitions</p> <p data-bbox="154 600 421 624">(1) Two types of tests</p> <p data-bbox="197 663 981 842">(B) Leak Test : A test to verify the tightness of a boundary. Unless a specific test is indicated, this may be a hydrostatic/hydropneumatic test or an air test. A hose test may be considered an acceptable form of leak test for certain boundaries, as indicated by Footnote (3) of Table 3.1.1.</p> <p data-bbox="120 890 344 914">4. Test Procedures</p> <p data-bbox="154 930 286 954">(1) General</p> <p data-bbox="197 978 981 1209">(A) Tests are to be carried out in the presence of a Surveyor at a stage sufficiently close to the completion of work with all hatches, doors, windows, etc. installed and all penetrations including pipe connections fitted, and before any ceiling and cement work is applied over the joints. Specific test requirements are given in (4) and Table 3.1.1. For the timing of the application of coating and the provision of safe access to joints, see (5), (6) and Table 3.1.2-1.</p>	<p data-bbox="1041 280 1854 344">Annex 1-16 Procedures for Testing Tanks and Tight Boundaries (2018)</p> <p data-bbox="1272 376 1619 408">PART A - SOLAS Ships</p> <p data-bbox="1032 419 1189 443">2. Application</p> <p data-bbox="1066 477 1892 536">(3) The testing of structures not listed in Table 3.1.1 1 or 3.1.2 2 is to be specially considered.</p> <p data-bbox="1032 568 1391 592">3. Tests Types and Definitions</p> <p data-bbox="1066 608 1332 632">(1) Two types of tests</p> <p data-bbox="1108 671 1892 850">(B) Leak Test : A test to verify the tightness of a boundary. Unless a specific test is indicated, this may be a hydrostatic/hydropneumatic test or an air test. A hose test may be considered an acceptable form of leak test for certain boundaries, as indicated by Footnote (3) of Table 3.1.1 1.</p> <p data-bbox="1032 898 1256 922">4. Test Procedures</p> <p data-bbox="1066 938 1198 962">(1) General</p> <p data-bbox="1108 986 1892 1217">(A) Tests are to be carried out in the presence of a Surveyor at a stage sufficiently close to the completion of work with all hatches, doors, windows, etc. installed and all penetrations including pipe connections fitted, and before any ceiling and cement work is applied over the joints. Specific test requirements are given in (4) and Table 3.1.1 1. For the timing of the application of coating and the provision of safe access to joints, see (5), (6) and Table 3.1.2-1 3.</p>	<p data-bbox="1917 284 2141 355">- Number system changes</p>

Present	Amendments	Reason
<p>(2) Structural test procedures</p> <p>(A) Type and time of test</p> <p>(a) Where a structural test is specified in Table 3.1.1 or Table 3.1.2, a hydrostatic test in accordance with (4) (A) will be acceptable. Where practical limitations (strength of building berth, light density of liquid, etc.) prevent the performance of a hydrostatic test, a hydropneumatic test in accordance with (4) (B) may be accepted instead.</p> <p>(B) Testing Schedule for New Construction or Major Structural Conversion</p> <p>(a) Tanks which are intended to hold liquids, and which form part of the watertight subdivision of the ship, shall be tested for tightness and structural strength as indicated in Table 3.1.1 or Table 3.1.2.</p> <p>(3) Leak test procedures</p> <p>(A) For the leak tests specified in Table 3.1.1, tank air tests, compressed air fillet weld tests, vacuum box test in accordance with (4) (D) through (4) (F), or their combination, will be acceptable. Hydrostatic or hydropneumatic tests may also be accepted as leak tests provided that (5), (6) and (7) are complied with. Hose tests will also be acceptable for such locations as specified in Table 3.1.1, note *3, in accordance with (4) (C). The application of the leak test for each type of welded joint is specified in Table 3.1.2-1.</p> <p>(B) Air tests of joints may be carried out in the block stage provided that all work on the block that may affect the tightness of a joint is completed before the test. See also (5) (A) for the application of final coatings and (6) for the safe access to joints and the summary in Table 3.1.2-2.</p>	<p>(2) Structural test procedures</p> <p>(A) Type and time of test</p> <p>(a) Where a structural test is specified in Table 3.1.1 1 or Table 3.1.2 2, a hydrostatic test in accordance with (4) (A) will be acceptable. Where practical limitations (strength of building berth, light density of liquid, etc.) prevent the performance of a hydrostatic test, a hydropneumatic test in accordance with (4) (B) may be accepted instead.</p> <p>(B) Testing Schedule for New Construction or Major Structural Conversion</p> <p>(a) Tanks which are intended to hold liquids, and which form part of the watertight subdivision of the ship, shall be tested for tightness and structural strength as indicated in Table 3.1.1 1 or Table 3.1.2 2.</p> <p>(3) Leak test procedures</p> <p>(A) For the leak tests specified in Table 3.1.1 1 tank air tests, compressed air fillet weld tests, vacuum box test in accordance with (4) (D) through (4) (F), or their combination, will be acceptable. Hydrostatic or hydropneumatic tests may also be accepted as leak tests provided that (5), (6) and (7) are complied with. Hose tests will also be acceptable for such locations as specified in Table 3.1.1 1 note *3, in accordance with (4) (C). The application of the leak test for each type of welded joint is specified in Table 3.1.2-1 3.</p> <p>(B) Air tests of joints may be carried out in the block stage provided that all work on the block that may affect the tightness of a joint is completed before the test. See also (5) (A) for the application of final coatings and (6) for the safe access to joints and the summary in Table 3.1.2-2 3.</p>	<p>- Number system changes</p>

Present	Amendments	Reason
<p>(4) Test Methods</p> <p>(A) Hydrostatic test</p> <p>(a) Unless another liquid is approved, hydrostatic tests are to consist of filling the space with fresh water or sea water, whichever is appropriate for testing to the level specified in Table 3.1.1 or Table 3.1.2.</p> <p>Also refer to 4. (7) "Hydrostatic or hydropneumatic tightness test.</p> <p>(5) Application of Coating</p> <p>(A) Final coating</p> <p>(c) For all other joints, the final coating is to be applied after the completion of the leak test of the joint. See also Table 3.1.2-1.</p> <p>(6) Safe access to joints</p> <p>For leak tests, a safe access to all joints under examination is to be provided. See also Table 3.1.2-1.</p> <p>Table 3.1.1 Test Requirements for Tanks and Boundaries Table 3.1.2 Additional Test Requirements for Special Service Ships/Tanks Table 3.1.2-1 Application of Leak Test, Coating and Provision of Safe Access for Type of Welded Joints</p>	<p>(4) Test Methods</p> <p>(A) Hydrostatic test</p> <p>(a) Unless another liquid is approved, hydrostatic tests are to consist of filling the space with fresh water or sea water, whichever is appropriate for testing to the level specified in Table 3.1.1 1 or Table 3.1.2 2.</p> <p>Also refer to 4. (7) "Hydrostatic or hydropneumatic tightness test.</p> <p>(5) Application of Coating</p> <p>(A) Final coating</p> <p>(c) For all other joints, the final coating is to be applied after the completion of the leak test of the joint. See also Table 3.1.2-1 3.</p> <p>(6) Safe access to joints</p> <p>For leak tests, a safe access to all joints under examination is to be provided. See also Table 3.1.2-1 3.</p> <p>Table 3.1.1 1 Test Requirements for Tanks and Boundaries Table 3.1.2 2 Additional Test Requirements for Special Service Ships/Tanks Table 3.1.2-1 3 Application of Leak Test, Coating and Provision of Safe Access for Type of Welded Joints</p>	<p>- Number system changes</p>

Present	Amendments	Reason
<p style="text-align: center;">PART B – Non-SOLAS Ships and SOLAS Exemption/Equivalent Ships</p> <p>2. APPLICATION</p> <p>(1) Testing procedures are to be carried out in accordance with the requirements of PART A in association with the following alternative procedures for 4. (2) (B) of PART A “Testing Schedule for New Construction or Major Structural Conversion” and alternative test requirements for PART A Table 3.1.1.</p> <p>(5) Where the structural adequacy of the tanks of a vessel were verified by the structural testing required in PART A, Table 3.1.1, subsequent vessels in the series (i.e. sister ships built from the same plans at the same shipyard) may be exempted from structural testing of tanks, provided that:</p> <p>(B) structural testing is carried out for at least one tank of “each type” among all tanks of each sister vessel. <i>(2022)</i></p> <p>Note : The expression of “each type” refers to the purpose of the tanks given in each row of Table 3.1.1 where the structural testing is required.</p>	<p style="text-align: center;">PART B – Non-SOLAS Ships and SOLAS Exemption/Equivalent Ships</p> <p>2. APPLICATION</p> <p>(1) Testing procedures are to be carried out in accordance with the requirements of PART A in association with the following alternative procedures for 4. (2) (B) of PART A “Testing Schedule for New Construction or Major Structural Conversion” and alternative test requirements for PART A Table 3.1.1 1.</p> <p>(5) Where the structural adequacy of the tanks of a vessel were verified by the structural testing required in PART A, Table 3.1.1 1, subsequent vessels in the series (i.e. sister ships built from the same plans at the same shipyard) may be exempted from structural testing of tanks, provided that:</p> <p>(B) structural testing is carried out for at least one tank of “each type” among all tanks of each sister vessel. <i>(2022)</i></p> <p>Note : The expression of “each type” refers to the purpose of the tanks given in each row of Table 3.1.1 1 where the structural testing is required.</p>	<p>- Number system changes</p>

PART 2

Present	Amendment	Note																
<p style="text-align: center;">(Rules) Pt 2</p> <p style="text-align: center;">CHAPTER 2 WELDING</p> <p style="text-align: center;">Section 4 Welding Procedure Qualification Tests</p> <p>407. Validity of qualified welding procedure specification</p> <p>2. Validity of variables for qualified WPS is as follows. However, it may be considered as equivalent for the requirements of the standard internationally recognized(AWS, ASME etc.) are applied.</p> <p>(2) Thickness and outer diameter of base metal</p> <p>(a) The qualification of a WPS carried out on a plate or pipe test assembly of thickness t is valid for the thickness range given in Table 2.2.13 and Table 2.2.14. (2019)</p> <p>Table 2.2.14 Range of qualification for parent material thickness (2019)</p> <table border="1" data-bbox="174 965 983 1197"> <thead> <tr> <th>Thickness of the test piece t (mm)</th> <th>Range of approval</th> </tr> </thead> <tbody> <tr> <td style="text-align: center;">$t \leq 3$</td> <td style="text-align: center;">$0.5t \sim 2t$</td> </tr> <tr> <td style="text-align: center;">$3 < t \leq 20$</td> <td style="text-align: center;">$3 \sim 2t$</td> </tr> <tr> <td style="text-align: center;">$t > 20$</td> <td style="text-align: center;">$\geq 0.8t$</td> </tr> </tbody> </table>	Thickness of the test piece t (mm)	Range of approval	$t \leq 3$	$0.5t \sim 2t$	$3 < t \leq 20$	$3 \sim 2t$	$t > 20$	$\geq 0.8t$	<p style="text-align: center;">(Rules) Pt 2</p> <p style="text-align: center;">CHAPTER 2 WELDING</p> <p style="text-align: center;">Section 4 Welding Procedure Qualification Tests</p> <p>407. Validity of qualified welding procedure specification</p> <p>2. Validity of variables for qualified WPS is as follows. However, it may be considered as equivalent for the requirements of the standard internationally recognized(AWS, ASME etc.) are applied.</p> <p>(2) Thickness and outer diameter of base metal</p> <p>(a) The qualification of a WPS carried out on a plate or pipe test assembly of thickness t is valid for the thickness range given in Table 2.2.13 and Table 2.2.14. (2019)</p> <p>Table 2.2.14 Range of Aluminium alloys qualification for parent material thickness (2019)</p> <table border="1" data-bbox="1041 965 1850 1197"> <thead> <tr> <th>Thickness of the test piece t (mm)</th> <th>Range of approval</th> </tr> </thead> <tbody> <tr> <td style="text-align: center;">$t \leq 3$</td> <td style="text-align: center;">$0.5t \sim 2t$</td> </tr> <tr> <td style="text-align: center;">$3 < t \leq 20$</td> <td style="text-align: center;">$3 \sim 2t$</td> </tr> <tr> <td style="text-align: center;">$t > 20$</td> <td style="text-align: center;">$\geq 0.8t$</td> </tr> </tbody> </table>	Thickness of the test piece t (mm)	Range of approval	$t \leq 3$	$0.5t \sim 2t$	$3 < t \leq 20$	$3 \sim 2t$	$t > 20$	$\geq 0.8t$	<p>일자: 2023.10.05. 조치담당: 최대곤 수석</p>
Thickness of the test piece t (mm)	Range of approval																	
$t \leq 3$	$0.5t \sim 2t$																	
$3 < t \leq 20$	$3 \sim 2t$																	
$t > 20$	$\geq 0.8t$																	
Thickness of the test piece t (mm)	Range of approval																	
$t \leq 3$	$0.5t \sim 2t$																	
$3 < t \leq 20$	$3 \sim 2t$																	
$t > 20$	$\geq 0.8t$																	

PART 3

Present	Amendments	Reason
<p style="text-align: center;">〈Rule Pt 3〉</p> <p style="text-align: center;">CHAPTER 8 FRAMES</p> <p style="text-align: center;">Section 4 Side Longitudinals</p> <p>401. Section modulus</p> <p>The section modulus of side longitudinals in the midship part below the freeboard deck is not to be less than that obtained from the following formula, whichever is the greater:</p> $Z_1 = 100CSht^2 \quad (\text{cm}^3), \quad Z_2 = 2.9K\sqrt{L}Sl^2 \quad (\text{cm}^3)$ <p>where:</p> <p>$S, l, h, L' = \langle \text{omitted} \rangle$</p> <p>$C = \langle \text{omitted} \rangle$</p> $C = \frac{K}{24 - \alpha K}$ <p>$\alpha = \langle \text{omitted} \rangle$</p> <p>$\beta = \langle \text{omitted} \rangle$</p> <p style="padding-left: 40px;">$\beta = 6/a$ when L is 230 m and under</p> <p style="padding-left: 40px;">$\beta = 10.5/a$ when L is 400 m and above</p> <p>For intermediate values of L, β is to be obtained by linear interpolation.</p> <p><u>Y' = the greater of the value specified in Pt 3, Ch 3, 203., (5) (a) or (b)</u></p> <p><u>$a = \sqrt{K}$, when high tensile steels are used for not less than 80% of side shell platings at the transverse section amidship and 1.0 for other parts.</u></p>	<p style="text-align: center;">〈Rule Pt 3〉</p> <p style="text-align: center;">CHAPTER 8 FRAMES</p> <p style="text-align: center;">Section 4 Side Longitudinals</p> <p>401. Section modulus</p> <p>The section modulus of side longitudinals in the midship part below the freeboard deck is not to be less than that obtained from the following formula, whichever is the greater:</p> $Z_1 = 100CSht^2 \quad (\text{cm}^3), \quad Z_2 = 2.9K\sqrt{L}Sl^2 \quad (\text{cm}^3)$ <p>where:</p> <p>$S, l, h, L' = \langle \text{omitted} \rangle$</p> <p>$C = \langle \text{omitted} \rangle$</p> $C = \frac{K}{24 - \alpha K}$ <p>$\alpha = \langle \text{omitted} \rangle$</p> <p>$\beta = \langle \text{omitted} \rangle$</p> <p style="padding-left: 40px;">$\beta = 6/a$ when L is 230 m and under</p> <p style="padding-left: 40px;">$\beta = 10.5/a$ when L is 400 m and above</p> <p>For intermediate values of L, β is to be obtained by linear interpolation.</p> <p><u>$a = \sqrt{K}$, when high tensile steels are used for not less than 80% of side shell platings at the transverse section amidship and 1.0 for other parts.</u></p> <p><u>y = vertical distance (m) from the top of keel to the longitudinal under consideration</u></p> <p><u>y_B = distance from the top of keel to the horizontal neutral axis of transverse section amidship (m).</u></p> <p><u>Y' = the greater of the value specified in Pt 3, Ch 3, 203., (5) (a) or (b)</u></p>	<p>- 국문판과 일치하도록 변경함.</p>

Present										Amendments										Reason																																																																																																																		
〈Guidance〉 CHAPTER 3 LONGITUDINAL STRENGTH Section 1 General										〈Guidance〉 CHAPTER 3 LONGITUDINAL STRENGTH Section 1 General																																																																																																																												
Table 3.3.3 For the case of ships, loading manual and longitudinal loading instruments are to be installed (2018)										Table 3.3.3 For the case of ships, loading manual and longitudinal loading instruments are to be installed (2018)																																																																																																																												
<table border="1"> <thead> <tr> <th rowspan="2">Kind of ship</th> <th colspan="2">Category 1-1</th> <th colspan="2">Category 1-2</th> <th colspan="2">Category 1-3</th> <th colspan="2">Category 2</th> </tr> <tr> <th>Application</th> <th></th> <th></th> <th></th> <th></th> <th></th> <th></th> <th></th> </tr> </thead> <tbody> <tr> <td>①</td> <td>〈omitted〉</td> <td>〈omitted〉</td> <td>〈omitted〉</td> <td>〈omitted〉</td> <td>〈omitted〉</td> <td>〈omitted〉</td> <td>〈omitted〉</td> <td>〈omitted〉</td> <td>〈omitted〉</td> </tr> <tr> <td>②</td> <td>〈omitted〉</td> <td>〈omitted〉</td> <td>〈omitted〉</td> <td>〈omitted〉</td> <td>〈omitted〉</td> <td>〈omitted〉</td> <td>〈omitted〉</td> <td>〈omitted〉</td> <td>〈omitted〉</td> </tr> <tr> <td>③</td> <td>〈omitted〉</td> <td>〈omitted〉</td> <td>〈omitted〉</td> <td>〈omitted〉</td> <td>〈omitted〉</td> <td>〈omitted〉</td> <td>〈omitted〉</td> <td>〈omitted〉</td> <td>〈omitted〉</td> </tr> <tr> <td>④</td> <td>〈omitted〉</td> <td>〈omitted〉</td> <td>〈omitted〉</td> <td>〈omitted〉</td> <td>〈omitted〉</td> <td>〈omitted〉</td> <td>〈omitted〉</td> <td>〈omitted〉</td> <td>〈omitted〉</td> </tr> </tbody> </table>										Kind of ship	Category 1-1		Category 1-2		Category 1-3		Category 2		Application								①	〈omitted〉	〈omitted〉	〈omitted〉	〈omitted〉	〈omitted〉	〈omitted〉	〈omitted〉	〈omitted〉	〈omitted〉	②	〈omitted〉	〈omitted〉	〈omitted〉	〈omitted〉	〈omitted〉	〈omitted〉	〈omitted〉	〈omitted〉	〈omitted〉	③	〈omitted〉	〈omitted〉	〈omitted〉	〈omitted〉	〈omitted〉	〈omitted〉	〈omitted〉	〈omitted〉	〈omitted〉	④	〈omitted〉	〈omitted〉	〈omitted〉	〈omitted〉	〈omitted〉	〈omitted〉	〈omitted〉	〈omitted〉	〈omitted〉	<table border="1"> <thead> <tr> <th rowspan="2">Kind of ship</th> <th colspan="2">Category 1-1</th> <th colspan="2">Category 1-2</th> <th colspan="2">Category 1-3</th> <th colspan="2">Category 2</th> </tr> <tr> <th>Application</th> <th></th> <th></th> <th></th> <th></th> <th></th> <th></th> <th></th> </tr> </thead> <tbody> <tr> <td>①</td> <td>〈omitted〉</td> <td>〈omitted〉</td> <td>〈omitted〉</td> <td>〈omitted〉</td> <td>〈omitted〉</td> <td>〈omitted〉</td> <td>〈omitted〉</td> <td>〈omitted〉</td> <td>〈omitted〉</td> </tr> <tr> <td>②</td> <td>〈omitted〉</td> <td>〈omitted〉</td> <td>〈omitted〉</td> <td>〈omitted〉</td> <td>〈omitted〉</td> <td>〈omitted〉</td> <td>〈omitted〉</td> <td>〈omitted〉</td> <td>〈omitted〉</td> </tr> <tr> <td>③</td> <td>〈omitted〉</td> <td>〈omitted〉</td> <td>〈omitted〉</td> <td>〈omitted〉</td> <td>〈omitted〉</td> <td>〈omitted〉</td> <td>〈omitted〉</td> <td>〈omitted〉</td> <td>〈omitted〉</td> </tr> <tr> <td>④</td> <td>〈omitted〉</td> <td>〈omitted〉</td> <td>〈omitted〉</td> <td>〈omitted〉</td> <td>〈omitted〉</td> <td>〈omitted〉</td> <td>〈omitted〉</td> <td>〈omitted〉</td> <td>〈omitted〉</td> </tr> </tbody> </table>										Kind of ship	Category 1-1		Category 1-2		Category 1-3		Category 2		Application								①	〈omitted〉	〈omitted〉	〈omitted〉	〈omitted〉	〈omitted〉	〈omitted〉	〈omitted〉	〈omitted〉	〈omitted〉	②	〈omitted〉	〈omitted〉	〈omitted〉	〈omitted〉	〈omitted〉	〈omitted〉	〈omitted〉	〈omitted〉	〈omitted〉	③	〈omitted〉	〈omitted〉	〈omitted〉	〈omitted〉	〈omitted〉	〈omitted〉	〈omitted〉	〈omitted〉	〈omitted〉	④	〈omitted〉	〈omitted〉	〈omitted〉	〈omitted〉	〈omitted〉	〈omitted〉	〈omitted〉	〈omitted〉	〈omitted〉	
Kind of ship	Category 1-1		Category 1-2		Category 1-3		Category 2																																																																																																																															
	Application																																																																																																																																					
①	〈omitted〉	〈omitted〉	〈omitted〉	〈omitted〉	〈omitted〉	〈omitted〉	〈omitted〉	〈omitted〉	〈omitted〉																																																																																																																													
②	〈omitted〉	〈omitted〉	〈omitted〉	〈omitted〉	〈omitted〉	〈omitted〉	〈omitted〉	〈omitted〉	〈omitted〉																																																																																																																													
③	〈omitted〉	〈omitted〉	〈omitted〉	〈omitted〉	〈omitted〉	〈omitted〉	〈omitted〉	〈omitted〉	〈omitted〉																																																																																																																													
④	〈omitted〉	〈omitted〉	〈omitted〉	〈omitted〉	〈omitted〉	〈omitted〉	〈omitted〉	〈omitted〉	〈omitted〉																																																																																																																													
Kind of ship	Category 1-1		Category 1-2		Category 1-3		Category 2																																																																																																																															
	Application																																																																																																																																					
①	〈omitted〉	〈omitted〉	〈omitted〉	〈omitted〉	〈omitted〉	〈omitted〉	〈omitted〉	〈omitted〉	〈omitted〉																																																																																																																													
②	〈omitted〉	〈omitted〉	〈omitted〉	〈omitted〉	〈omitted〉	〈omitted〉	〈omitted〉	〈omitted〉	〈omitted〉																																																																																																																													
③	〈omitted〉	〈omitted〉	〈omitted〉	〈omitted〉	〈omitted〉	〈omitted〉	〈omitted〉	〈omitted〉	〈omitted〉																																																																																																																													
④	〈omitted〉	〈omitted〉	〈omitted〉	〈omitted〉	〈omitted〉	〈omitted〉	〈omitted〉	〈omitted〉	〈omitted〉																																																																																																																													
<ol style="list-style-type: none"> 1. 〈omitted〉 2. 〈omitted〉 3. For the application ① to ⑤, they means application date for the ships under the survey of during construction and construction date for the ships under the survey after construction. 4. (A) : For the ships having not exceeding 120 m in length and reflected in design for non-homogeneous cargo loading, it is specified in category 2 and longitudinal loading instrument may be not installed. 5. (B) : For the ships in category 2 with not exceeding 90 m in length and dead weight is not exceed 30 % of fully loaded displacement, longitudinal loading instrument may be not installed. 6. (C) : For all bulk carriers, ore carriers and combination carriers, longitudinal loading instrument is to be installed until 1 Jan 1999. 7. (D) : The ships less than 100 m in length may not be provided with a loading manual where deemed unnecessary by the Society. 8. For the ships exempted the installation of longitudinal loading instrument may be not installed, when the instruments is installed, they are to be complied with related regulations. 										<ol style="list-style-type: none"> 1. 〈omitted〉 2. 〈omitted〉 3. For the application ① to ⑤④, they means application date for the ships under the survey of during construction and construction date for the ships under the survey after construction. 4. (A) : For the ships having not exceeding 120 m in length and reflected in design for non-homogeneous cargo loading, it is specified in category 2 and longitudinal loading instrument may be not installed. 5. (B) : For the ships in category 2 with not exceeding 90 m in length and dead weight is not exceed 30 % of fully loaded displacement, longitudinal loading instrument may be not installed. 6. (C) : For all bulk carriers, ore carriers and combination carriers, longitudinal loading instrument is to be installed until 1 Jan 1999. 7. (D) : The ships less than 100 m in length may not be provided with a loading manual where deemed unnecessary by the Society. 8. For the ships exempted the installation of longitudinal loading instrument may be not installed, when the instruments is installed, they are to be complied with related regulations. 										<p>- 2018년 개정작업시 “⑤” 삭제되었으나 비고란에는 삭제 누락.</p>																																																																																																																		

Present	Amendment	Note
<p style="text-align: center;">Present</p> <p style="text-align: center;">〈Rule Pt 3〉</p> <p style="text-align: center;">CHAPTER 16 SUPERSTRUCTURES</p> <p style="text-align: center;">Section 2 Superstructure End Bulkheads</p> <p>202. Thickness</p> <p>1. The thickness of superstructure end bulkhead plating is not to be less than that obtained from the following formula:</p> $t = 3S\sqrt{hK} \quad (\text{mm})$ <p>〈omit〉</p> <p>2. The thickness of bulkhead plating is not to be less than that obtained from the following formula or 5 mm, whichever is the greater, irrespective of the provisions in Par 1. (2023)</p> <p>Bulkhead plating of the first tier superstructure : $t = \frac{L'}{100} + 4.0$ (mm)</p> <p>Plating of other bulkheads : $t = \frac{L'}{100} + 3.0$ (mm)</p> <p>where:</p> <p>L' = as specified in Table 3.16.1.</p> <p>〈omit〉</p>	<p style="text-align: center;">Amendment</p> <p style="text-align: center;">〈Rule Pt 3〉</p> <p style="text-align: center;">CHAPTER 16 SUPERSTRUCTURES</p> <p style="text-align: center;">Section 2 Superstructure End Bulkheads</p> <p>202. Thickness</p> <p>1. The thickness of superstructure end bulkhead plating is not to be less than that obtained from the following formula:</p> $t = 3S\sqrt{hK} \quad (\text{mm})$ <p>〈same as current〉</p> <p>2. The thickness of bulkhead plating is not to be less than that obtained from the following formula or 5 mm, whichever is the greater, irrespective of the provisions in Par 1. (2023)</p> <p>Bulkhead plating of the first tier superstructure : $t = \frac{L'}{100} + 5.0$ (mm)</p> <p>Plating of other bulkheads : $t = \frac{L'}{100} + 4.0$ (mm)</p> <p>where:</p> <p>L' = as specified in Table 3.16.1.</p> <p>〈same as current〉</p>	<p style="text-align: center;">Note</p> <p style="text-align: center;">〈Rule Pt 3〉</p> <p style="text-align: center;">CHAPTER 16 SUPERSTRUCTURES</p> <p style="text-align: center;">Section 2 Superstructure End Bulkheads</p> <p>202. Thickness</p> <p>1. The thickness of superstructure end bulkhead plating is not to be less than that obtained from the following formula:</p> $t = 3S\sqrt{hK} \quad (\text{mm})$ <p>〈same as current〉</p> <p>2. The thickness of bulkhead plating is not to be less than that obtained from the following formula or 5 mm, whichever is the greater, irrespective of the provisions in Par 1. (2023)</p> <p>Bulkhead plating of the first tier superstructure : $t = \frac{L'}{100} + 5.0$ (mm)</p> <p>Plating of other bulkheads : $t = \frac{L'}{100} + 4.0$ (mm)</p> <p>where:</p> <p>L' = as specified in Table 3.16.1.</p> <p>〈same as current〉</p> <p style="text-align: right;">- UR S3 요건 오기 반영</p>

Present	Amendment	Note
<p style="text-align: center; color: blue;">〈Guidance Pt 3〉</p> <p style="text-align: center;">Section 4 Watertight Door</p> <p>402. Type of watertight doors [See Rule]</p> <ol style="list-style-type: none"> 1. Watertight doors provided in watertight bulkheads are to be sliding type as far as practicable. If hinged doors are used, they are to be accessible at any time and, further, to be protected against damages due to cargoes, etc. by suitable means. 2. For passenger ships the watertight doors and their controls are to be located in compliance with SOLAS II-1/13.5.3 and II-1/13.7.1.2.2. 	<p style="text-align: center; color: blue;">〈Guidance Pt 3〉</p> <p style="text-align: center;">Section 4 Watertight Door</p> <p>402. Type of watertight doors [See Rule]</p> <ol style="list-style-type: none"> 1. Watertight doors provided in watertight bulkheads are to be sliding type as far as practicable. If hinged doors are used, they are to be accessible at any time and, further, to be protected against damages due to cargoes, etc. by suitable means. 2. For passenger ships the watertight doors and their controls are to be located in compliance with Table 3.14.3 and SOLAS II-1/13.5.3, II-1/13.7.1.2.2. 	

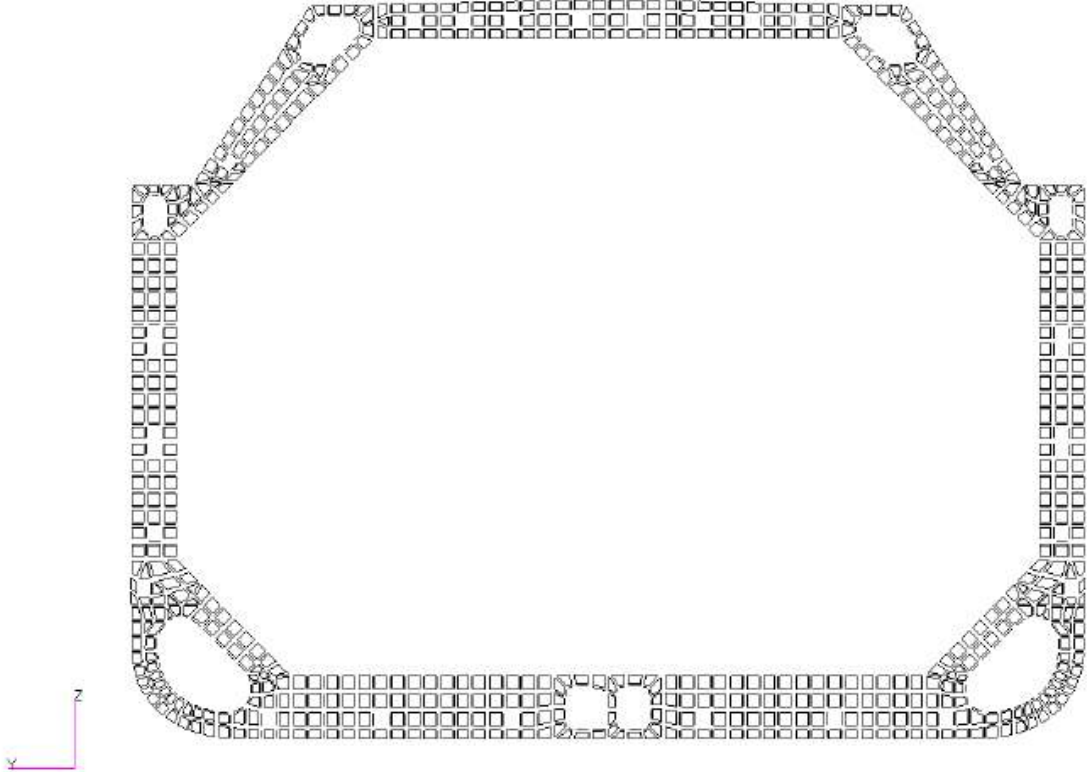
Present	Amendment	Reason
<p data-bbox="120 236 439 272">Annex 3-2 <omitted></p> <p data-bbox="120 339 275 368">III. <omitted></p> <p data-bbox="120 392 266 421">7. <omitted></p> <p data-bbox="154 467 329 496"><Newly added></p>	<p data-bbox="992 236 1245 272" style="color: blue;"><Guidance Pt.3></p> <p data-bbox="689 300 1547 336">Annex 3-2 Guidance for the Direct Strength Assessment</p> <p data-bbox="524 403 938 432">III. Guidance for the Hold Analysis</p> <p data-bbox="524 456 1296 485">7. Structural Analysis Procedure for Membrane Tank LNG Carriers</p> <div data-bbox="586 539 1671 1318" style="text-align: center;">  </div> <p data-bbox="927 1353 1368 1382">Fig 37 Typical F.E. Model of a web frame</p>	<p data-bbox="1783 467 1995 536">- Fig 37 is missing (English only).</p>

Present	Amendment	Reason
<p style="text-align: center;">Present</p> <p style="text-align: center;"><Guidance Pt. 3></p> <p style="text-align: center;">Annex 3-2 Guidance for the Direct Strength Assessment</p> <p>I. General <omitted></p> <p>II. Direct Global Structural Analysis <omitted></p> <p>III. Guidance for the Hold Analysis</p> <p>1. ~ 7. <omitted></p> <p>8. LPG Carriers with Independent Tank Type A</p> <p>(1) General <omitted></p> <p>(2) Structural modelling</p> <p>(A) ~ (B) <omitted></p> <p>(C) Properties and Corrosion Allowance</p> <p>(a) The properties of FE models for cargo hold region including local structural strength are to be based on the gross scantling approach for yielding and net thickness approach for buckling, applying a thickness deduction as defined in Ch 3, Sec 4 Table 3.3.3 of the Rule if not defined specifically. In net thickness application, only plate members are considered.</p> <p>(b) For the independent tank structure made of stainless steel, there is no need to apply the thickness deduction in general.</p> <p>(D) Supporting Structure Idealization <omitted></p> <p>(3) ~ (5) <omitted></p> <p>(6) Loads</p> <p>(A) ~ (E) <omitted></p> <p>(F) Design Load Case</p> <p>(a) In seagoing phase, full load condition with scantling draft, alternate load condition and ballast condition with minimum draft are to be check for structural strength.</p>	<p style="text-align: center;">Amendment</p> <p style="text-align: center;"><Guidance Pt. 3></p> <p style="text-align: center;">Annex 3-2 Guidance for the Direct Strength Assessment</p> <p>I. General <same as the current Rules></p> <p>II. Direct Global Structural Analysis <same as the current Rules></p> <p>III. Guidance for the Hold Analysis</p> <p>1. ~ 7. <same as the current Rules></p> <p>8. LPG Carriers with Independent Tank Type A</p> <p>(1) General <same as the current Rules></p> <p>(2) Structural modelling</p> <p>(A) ~ (B) <same as the current Rules></p> <p>(C) Properties and Corrosion Allowance</p> <p>(a) The properties of FE models for cargo hold region including local structural strength are to be based on the gross scantling approach for yielding and net thickness approach for buckling, applying a thickness deduction as defined in Ch 3, Sec 4 Table 3.3.3 of the Rule if not defined specifically. In net thickness application, only plate members are considered.</p> <p>(b) For the independent tank structure made of stainless steel, there is no need to apply the thickness deduction in general.</p> <p>(D) Supporting Structure Idealization <same as the current Rules></p> <p>(3) ~ (5) <same as the current Rules></p> <p>(6) Loads</p> <p>(A) ~ (E) <same as the current Rules></p> <p>(F) Design Load Case</p> <p>(a) In seagoing phase, full load condition with scantling draft, alternate load condition and ballast condition with minimum draft are to be check for structural strength.</p>	<p>The corrosion addition value is defined in the</p> <p>IV. Buckling strength calculation.</p>

(b) For the harbour phase, any alternate loading condition is to be assessed. In that case, the static sea pressure and internal pressure are used considering overflow height. If the harbour phase is not specified in Loading Manual, the assessment for harbour condition may be omitted.

(7) Allowable Stress (omitted)

(8) Buckling Strength

Buckling strength is to be calculated according to **IV. Buckling strength calculation**. Buckling strength is to satisfy the criteria defined in 1 (5) of **IV. Buckling strength calculation** based on static+dynamic load combination except below load cases.

Load cases based on static load combination in 1 (5) of **IV.**

Buckling strength calculation:

- Table 46 and 47: LC9, LC10 and LC11,
- Table 48: LC9 and LC10,
- Table 49: LC8, LC9 and LC10.

However, for the cargo hold structural members under intact load cases, following enforced buckling criterion is to be applied.

$$\eta_{act} \leq 0.9 \eta_{all}$$

where:

η_{act} , η_{all} : refer to 1 (5) of **IV. Buckling strength calculation**.

IV. Buckling strength calculation (omitted) ↓

(b) For the harbour phase, any alternate loading condition is to be assessed. In that case, the static sea pressure and internal pressure are used considering overflow height. However, if any alternate loading condition is not specified in Loading Manual, the assessment for alternate loading condition may be omitted.

(7) Allowable Stress (same as the current Rules)

(8) Buckling Strength

Buckling strength is to be calculated according to **IV. Buckling strength calculation**. Buckling strength is to satisfy the criteria defined in 1 (5) of **IV. Buckling strength calculation** based on static+dynamic load combination except below load cases.

Load cases based on static load combination in 1 (5) of **IV.**

Buckling strength calculation:

- Table 46 and 47: LC9 and LC10 LC11,
- Table 48: LC8 and LC9 LC10,
- Table 49: LC8 and LC9 LC10.

However, for the cargo hold structural members under intact load cases, following enforced buckling criterion is to be applied.

$$\eta_{act} \leq 0.9 \eta_{all}$$

where:

η_{act} , η_{all} : refer to 1 (5) of **IV. Buckling strength calculation**.

IV. Buckling strength calculation (same as the current Rules) ↓

'harbour condition' corrected to 'alternate loading condition'

Load case errors

Annex 3-3 Guidance for the Fatigue Strength Assessment of Ship Structures

1. ~ 3. <omitted>

4. Simplified fatigue analysis

The simplified fatigue analysis based on stress concentration factor is to be used to evaluate the fatigue strength of the longitudinal stiffener end connection. The hull girder bending load and the local load are taken into account in this analysis. The former accounts for the vertical wave bending moment and the horizontal wave bending moment, and the latter for the wave load. In this guidance, the loads are determined at the probability level of exceedance 10^{-4} .

(1) ~ (4) <omitted>

(5) Calculation of fatigue damage ratio

(A) According to the Miner-Palmgren linear cumulative damage rule, the fatigue damage ratio D is calculated using numerical integration as follows:

$$D = \sum \frac{n_i}{N_i}$$

where,

n_i = number of stress cycles in stress block i for long-term distribution of the combined stress range

N_i = number of cycles to failure at the i -th constant stress range.

If the long-term distribution of the stress range follows a Weibull one, the damage ratio D_{air} is given by the following formula:

Annex 3-3 Guidance for the Fatigue Strength Assessment of Ship Structures

1. ~ 3. <same as the current Rules>

4. Simplified fatigue analysis

The simplified fatigue analysis based on stress concentration factor is to be used to evaluate the fatigue strength of the longitudinal stiffener end connection. The hull girder bending load and the local load are taken into account in this analysis. The former accounts for the vertical wave bending moment and the horizontal wave bending moment, and the latter for the wave load. In this guidance, the loads are determined at the probability level of exceedance 10^{-4} .

(1) ~ (4) <same as the current Rules>

(5) Calculation of fatigue damage ratio

(A) According to the Miner-Palmgren linear cumulative damage rule, the fatigue damage ratio D is calculated using numerical integration as follows:

$$D = \sum \frac{n_i}{N_i}$$

where,

n_i = number of stress cycles in stress block i for long-term distribution of the combined stress range

N_i = number of cycles to failure at the i -th constant stress range.

If the long-term distribution of the stress range follows a Weibull one, the damage ratio D_{air} is given by the following formula:

$$D_{air} = \frac{N_t}{K_2} \frac{\Delta\sigma_0^m}{(\ln N_0)^{m/\xi}} \cdot \mu_7 \cdot \Gamma\left(1 + \frac{m}{\xi}\right)$$

where,

K_2 = Constant of the design S-N curve, as given in **Table 1** (a) for in-air environment

ξ = Weibull shape parameter

Γ = complete Gamma function given by the following formula

$$\Gamma(z) = \int_0^{\infty} t^{z-1} e^{-t} dt$$

γ = incomplete Gamma function given by the following formula.

$$\gamma(z, x) = \int_0^x t^{z-1} e^{-t} dt$$

μ_7 = Coefficient taking into account the change of inverse slope of the S-N curve, m .

$$\mu_7 = 1 - \frac{\left\{ \gamma\left(1 + \frac{m}{\xi}, t_7\right) - t_7^{-\frac{2}{\xi}} \cdot \gamma\left(1 + \frac{m+2}{\xi}, t_7\right) \right\}}{\Gamma\left(1 + \frac{m}{\xi}\right)}$$

t_7 = as specified in the following formula

$$t_7 = \left(\frac{\Delta\sigma_7}{\Delta\sigma_0} \right)^{\xi} \ln N_0$$

$\Delta\sigma_7$ = stress range of the design S-N curve at

$$D_{air} = \frac{N_t}{K_2} \frac{\Delta\sigma_0^m}{(\ln N_0)^{m/\xi}} \cdot \mu_7 \cdot \Gamma\left(1 + \frac{m}{\xi}\right)$$

where,

K_2 = Constant of the design S-N curve, as given in **Table 1** (a) for in-air environment

N_0 = Number of cycles corresponding to the reference probability of exceedance of 10^{-4} .

$$N_0 = 10000$$

ξ = Weibull shape parameter

Γ = complete Gamma function given by the following formula

$$\Gamma(z) = \int_0^{\infty} t^{z-1} e^{-t} dt$$

γ = incomplete Gamma function given by the following formula.

$$\gamma(z, x) = \int_0^x t^{z-1} e^{-t} dt$$

μ_7 = Coefficient taking into account the change of inverse slope of the S-N curve, m .

$$\mu_7 = 1 - \frac{\left\{ \gamma\left(1 + \frac{m}{\xi}, t_7\right) - t_7^{-\frac{2}{\xi}} \cdot \gamma\left(1 + \frac{m+2}{\xi}, t_7\right) \right\}}{\Gamma\left(1 + \frac{m}{\xi}\right)}$$

t_7 = as specified in the following formula

$$t_7 = \left(\frac{\Delta\sigma_7}{\Delta\sigma_0} \right)^{\xi} \ln N_0$$

$\Delta\sigma_7$ = stress range of the design S-N curve at

Missing definition of the N_0

$$N = 10^7 \text{ cycles}$$

N_t = the total number of stress cycles for a design life of ships and considering voyage days of 85% for the design life of Y (years), the total number of stress cycles is given by the following formula.

$$N_t = \frac{2.68 \times 10^7}{4 \log L} \times Y$$

(B) ~ (C) <omitted>

(6) <omitted>

5. ~ 7. <omitted> ↓

$$N = 10^7 \text{ cycles}$$

N_t = the total number of stress cycles for a design life of ships and considering voyage days of 85% for the design life of Y (years), the total number of stress cycles is given by the following formula.

$$N_t = \frac{2.68 \times 10^7}{4 \log L} \times Y$$

(B) ~ (C) <same as the current Rules>

(6) <same as the current Rules>

5. ~ 7. <same as the current Rules> ↓

PART 4

Present	Amendment	Note
<p style="text-align: center;"><Rule Pt 4></p> <p style="text-align: center;">CHAPTER 4 BULWARKS, FREEING PORTS, SIDE SCUTTLES, RECTANGULAR WINDOWS, VENTILATORS AND PERMANENT GANGWAYS</p> <p style="text-align: center;">Section 1 Bulwarks and Guardrails <omitted> Section 2 Freeing Ports <omitted> Section 3 Side Scuttles, Rectangular Windows and Skylights</p> <p>301. General [See Guidance] <omitted> 302. Position of side scuttles <omitted> 303. Application of side scuttles [See Guidance]</p> <p>1.~ 4. <omitted></p> <p>5. Side scuttles fitted in spaces which give direct access to an open stairway and provided in deckhouse and companion which protect the openings specified in below, are to be type A, type B side scuttle with dead light or equivalent thereto. Where cabin bulkhead or doors separate side scuttles from a direct access leading below the freeboard deck, the dead light could be omitted.</p> <p>6.~7. <omitted></p>	<p style="text-align: center;"><Rule Pt 4></p> <p style="text-align: center;">CHAPTER 4 BULWARKS, FREEING PORTS, SIDE SCUTTLES, RECTANGULAR WINDOWS, VENTILATORS AND PERMANENT GANGWAYS</p> <p style="text-align: center;">Section 1 Bulwarks and Guardrails <same as present> Section 2 Freeing Ports <same as present> Section 3 Side Scuttles, Rectangular Windows and Skylights</p> <p>301. General [See Guidance] <same as present> 302. Position of side scuttles <same as present> 303. Application of side scuttles [See Guidance]</p> <p>1.~ 4. <omitted></p> <p>5. Side scuttles fitted in spaces which give direct access to an open stairway and provided in deckhouse and companion which protect the openings specified in below, are to be type A, type B side scuttle with dead light or equivalent thereto. Where cabin bulkhead or doors separate side scuttles from a direct access leading below the freeboard deck, the dead light could be omitted.</p> <p><u>(1) The opening in the superstructure deck which gives access to the spaces below the freeboard deck or within an enclosed superstructure.</u> <u>(2) The opening in the top of deckhouse on the freeboard deck which gives access to spaces below the freeboard deck.</u></p> <p>6.~7. <omitted></p> <p><u>8. Side scuttles shall be of the non-opening type in ships subject to damage stability regulations, if calculations indicate that they would become immersed by any intermediate stage of flooding or the final equilibrium waterplane in any required damage case.</u></p>	<p>Correction of omissions.</p>

Present	Amendment	Note
	<p><u>9. Deckhouses situated on a raised quarter deck or on the deck of a superstructure of less than standard height or on the deck of a deckhouse of less than standard height, may be regarded as being in the second tier as far as the provision of deadlights is concerned, provided the height of the raised quarter deck, superstructure or deckhouse is equal to, or greater than, the standard quarter deck height.</u></p>	<p>Correction of omissions.</p>

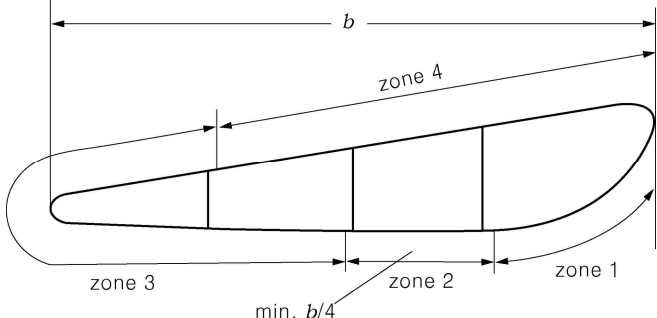
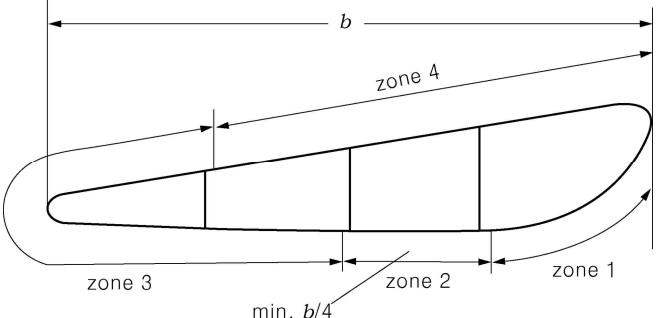
Present	Amendment	Note
<p style="text-align: center;"><Rule Pt 4></p> <p style="text-align: center;">CHAPTER 1 RUDDERS</p> <p style="text-align: center;">Section 1 ~ Section 10 <omitted> Section 11 Propeller Nozzles</p> <p>1101. Application ~ 1103. Plate thickness <omitted> 1104. Section modulus</p> <p>(1) The section modulus of the cross section shown in Fig 4.1.6 around its neutral axis is not to be less than:</p> $W = n \cdot d^2 \cdot b \cdot V^2 \quad (\text{cm}^3)$ <p>d = inner diameter of nozzle in (m) b = length of nozzle in (m) n = 1.0 for rudder nozzles = 0.7 for fixed nozzles. V = speed of ship(Kt) as specified in 201.</p>  <p style="text-align: center;">Fig 4.1.6 Propeller zone</p>	<p style="text-align: center;"><Rule Pt 4></p> <p style="text-align: center;">CHAPTER 1 RUDDERS</p> <p style="text-align: center;">Section 1 ~ Section 10 <same as the present> Section 11 Propeller Nozzles</p> <p>1101. Application ~ 1103. Plate thickness <same as the present> 1104. Section modulus</p> <p>(1) The section modulus of the cross section shown in Fig 4.1.8 around its neutral axis is not to be less than:</p> $W = n \cdot d^2 \cdot b \cdot V^2 \quad (\text{cm}^3)$ <p>d = inner diameter of nozzle in (m) b = length of nozzle in (m) n = 1.0 for rudder nozzles = 0.7 for fixed nozzles. V = speed of ship(Kt) as specified in 201.</p>  <p style="text-align: center;">Fig 4.1.8 Propeller zone</p>	<p>Correction error</p>

Present	Amendment	Note
<p style="text-align: center;">CHAPTER 2 HATCHWAYS AND OTHER DECK OPENINGS</p> <p style="text-align: center;">Section 1 ~ Section 4 <omitted> Section 5 Hatch cover details – Closing Arrangement, Securing Devices and Stoppers</p> <p>501. Weathertightness ~ 502. General<omitted> 503. Gaskets</p> <p>1. ~ 9. <omitted></p> <p>10. Exemption of gaskets</p> <p>In case of container ship accordance with the following requirements, gaskets may be omitted and clamping devices for steel hatchway covers may be suitably dispensed.</p> <p>(1) The hatchway coamings should be not less than 600 mm in height.</p> <p>(2) The exposed deck on which the hatch covers are located is situated above a depth H(x). H(x) is to be shown to comply with the following criteria:</p> $H(x) \geq T_{fp} + f_b + h'_N \quad (\text{m})$ <p>T_{fp} = draught, in m, corresponding to the assigned summer load line</p> <p>f_b = minimum required freeboard, in m, determined in accordance with ICLL Reg. 28 as modified by further regulations as applicable</p> $h'_N = 4.6 \text{ m for } \frac{x}{L_{LL}} \leq 0,75$ $= 6.9 \text{ m for } \frac{x}{L_{LL}} > 0,75$	<p style="text-align: center;">CHAPTER 2 HATCHWAYS AND OTHER DECK OPENINGS</p> <p style="text-align: center;">Section 1 ~ Section 4 <same as the present> Section 5 Hatch cover details – Closing Arrangement, Securing Devices and Stoppers</p> <p>501. Weathertightness ~ 502. General<same as the present> 503. Gaskets</p> <p>1. ~ 9. <same as the present></p> <p>10. Exemption of gaskets</p> <p>In case of container ship accordance with the following requirements, gaskets may be omitted and clamping devices for steel hatchway covers may be suitably dispensed.</p> <p>(1) The hatchway coamings should be not less than 600 mm in height.</p> <p>(2) The exposed deck on which the hatch covers are located is situated above a depth H(x). H(x) is to be shown to comply with the following criteria:</p> $H(x) \geq T_{fp} + f_b + h'_N \quad (\text{m})$ <p>T_{fp} = draught, in m, corresponding to the assigned summer load line</p> <p>f_b = minimum required freeboard, in m, determined in accordance with ICLL Reg. 28 as modified by further regulations as applicable</p> $h'_N = 4.6 \text{ m for } \frac{x}{L_f} \leq 0.75$ $= 6.9 \text{ m for } \frac{x}{L_f} > 0.75$	<p style="text-align: right;">Correction error</p>

Present	Amendment	Note
<p style="text-align: center;">CHAPTER 8 EQUIPMENT NUMBER AND EQUIPMENT</p> <p style="text-align: center;">Section 1 General</p> <p>101. General and application [See Guidance]</p> <p>1. ~ 3. <omitted></p> <p>4. All ships are to be provided with suitable appliances for handling of anchors as follows.</p> <p>(1) General</p> <p>(A) All ships are to be provided with suitable appliances for handling of anchors.</p> <p>(B) The bower anchors given in Table 4.8.1 are to be connected to their cables and stored on board ready for use. Anchor and chain cable are should be accordance with Sec 3, 4.</p> <p>(2) Chain locker</p> <p>(A) Chain locker is to have adequate capacity and be of a suitable from to provide for the proper stowage of the chain cable, allowing an easy direct lead for the cable into the chain pipes when the cable is fully stowed. Port and star-board cables are to have separate spaces.</p> <p>(B) <u>Chain locker boundaries and access opening are to be watertight.</u></p> <p><below omitted></p> <p style="text-align: center;">Section 2 Equipment Number</p> <p>201. Equipment number (2022) [See Guidance]</p>	<p style="text-align: center;">CHAPTER 8 EQUIPMENT NUMBER AND EQUIPMENT</p> <p style="text-align: center;">Section 1 General</p> <p>101. General and application [See Guidance]</p> <p>1. ~ 3. <omitted></p> <p>4. All ships are to be provided with suitable appliances for handling of anchors as follows.</p> <p>(1) General</p> <p>(A) All ships are to be provided with suitable appliances for handling of anchors.</p> <p>(B) The bower anchors given in Table 4.8.1 are to be connected to their cables and stored on board ready for use. Anchor and chain cable are should be accordance with Sec 3, 4.</p> <p>(2) Chain locker</p> <p>(A) Chain locker is to have adequate capacity and be of a suitable from to provide for the proper stowage of the chain cable, allowing an easy direct lead for the cable into the chain pipes when the cable is fully stowed. Port and star-board cables are to have separate spaces.</p> <p>(B) <u>Chain locker boundaries and access opening are to be watertight and adequate drainage facilities for the chain locker are to be provided.</u></p> <p><below omitted></p> <p style="text-align: center;">Section 2 Equipment Number</p> <p>201. Equipment number (2022) [See Guidance]</p>	<p>Correction of omission.</p>

Present

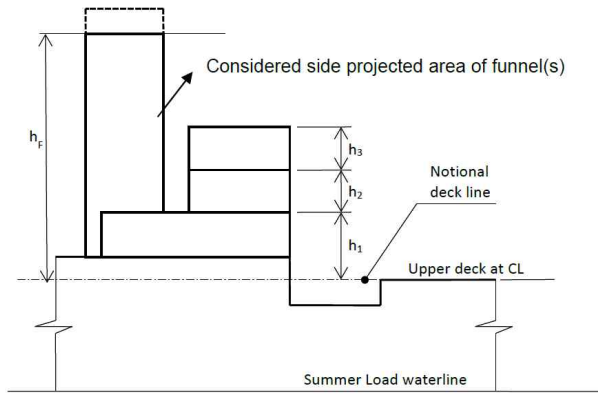

Figure 4.8.1

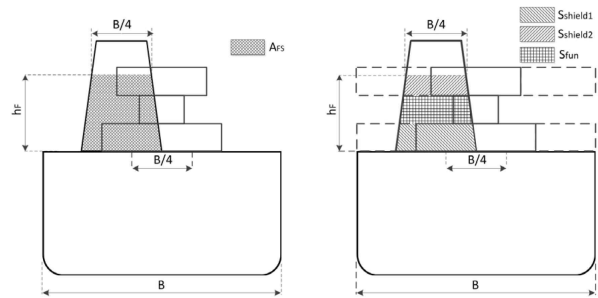

Figure 4.8.2

Amendment

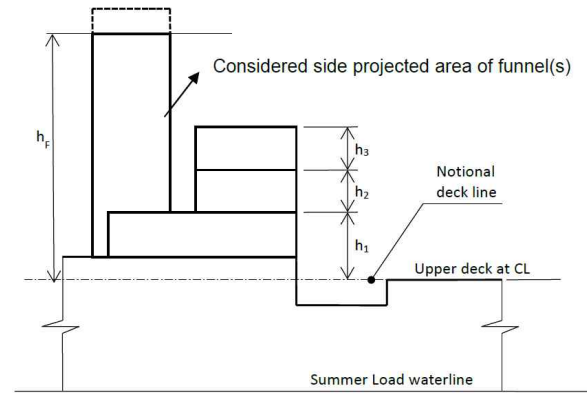

Fig 4.8.1

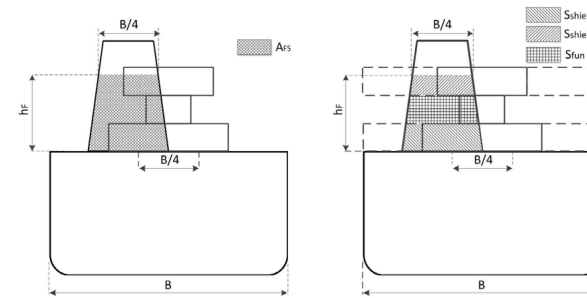

Fig 4.8.2

Note

Correction error

Present	Amendment	Note
<p data-bbox="107 240 954 408">CHAPTER 11 ACCESS TO AND WITHIN SPACES IN, AND FORWARD OF, THE CARGO AREA OF OIL TANKERS AND BULK CARRIERS</p> <p data-bbox="107 440 954 539">Section 1 General <omitted> Section 2 Technical Provisions for Means of Access for Inspections <omitted></p> <p data-bbox="107 563 954 616"><u>Table 4.11.1 – Means of access for ballast and cargo tanks of oil tankers (Access to the underdeck and vertical structure)</u></p>	<p data-bbox="999 240 1845 408">CHAPTER 11 ACCESS TO AND WITHIN SPACES IN, AND FORWARD OF, THE CARGO AREA OF OIL TANKERS AND BULK CARRIERS</p> <p data-bbox="999 440 1845 539">Section 1 General <omitted> Section 2 Technical Provisions for Means of Access for Inspections <omitted></p> <p data-bbox="999 563 1845 616"><u>Table 4.11.1 Means of access for ballast and cargo tanks of oil tankers (Access to the underdeck and vertical structure)</u></p>	<p data-bbox="1890 576 2130 639">Correction of omission.</p>

PART 7

Amendment	Note
<p style="text-align: center;">PART 7 Ships of Special Service (Ch1-4, 7-10)</p> <p style="text-align: center;">Annex 7-6-1 Water Level Detectors on Multiple Hold Cargo Ships other than Bulk Carriers and Tankers (2023)</p> <p style="text-align: center;">Section 1 General</p> <p>1. Application</p> <p>(1) Multiple hold cargo ships other than bulk carriers and tankers constructed on or after 1 January 2024¹ shall be fitted with water level detectors² in each cargo hold intended for dry cargoes. Water level detectors are not required for cargo holds located entirely above the freeboard deck.</p> <p>(2) The water level detectors required by paragraph (1) shall:</p> <p>(A) give audible and visual alarms at the navigation bridge, one when the water level above the bottom of the cargo hold reaches a height of not less than 0.3 m, and another at a height not less than 15% of the depth of the cargo hold but not more than 2 m; and</p> <p>(B) be fitted at the aft end of the cargo holds. For cargo holds which are occasionally used for water ballast, an alarm overriding device may be installed. The visual alarms shall clearly discriminate between the two different water levels detected in each hold.</p> <p>(3) As an alternative to the water level detector at a height of not less than 0.3 m as per sub-paragraph (2). (A), a bilge level sensor² serving the bilge pumping arrangements required by SOLAS II-1 regulation 35-1 and installed in the cargo hold bilge wells or other suitable location is considered acceptable, subject to:</p> <p>(A) the fitting of the bilge level sensor at a height of not less than 0.3 m at the aft end of the cargo hold; and</p> <p>(B) the bilge level sensor giving audible and visual alarm at the navigation bridge which is clearly distinctive from the alarm given by the other water level detector fitted in the cargo hold.</p> <p>* Footnotes:</p> <p>1. “constructed on or after 1 January 2024” means ships (SOLAS Reg. II-1/1.3.2):</p> <p>.1 for which the building contract is placed on or after 1 January 2024; or</p> <p>.2 in the absence of a building contract, the keel of which is laid or which are at a similar stage of construction on or after 1 July 2024; or</p> <p>.3 the delivery of which is on or after 1 January 2028.</p> <p>2. For the performance standards, Refer to Resolution MSC.188(79)/Rev.12 as may be amended. ↓</p>	<p>- MSC.188(79) w as revised according to MSC 107.</p>

Present	Amendment	Note
<p style="text-align: center;"> Present <Rules> Pt 7 CONTENTS CHAPTER 9 <u>TUGS</u> 177 CHAPTER 9 <u>TUGS</u> Section 1 General 101. Application 1. The construction and equipment of ships intended to be registered as "<u>Tug</u>" are to be in accordance with the requirements in this Chapter. The construction and equipment of ships intended to be registered as "Offshore Tug/Supply Ships" are to be in accordance with the requirements of Ch 8. Section 4 Panting and Strengthening of Bottom Forward 401. Panting region reinforcement The arrangements to resist panting required by Pt 3, Ch 9 do not apply to <u>tugs</u> less than 46 m in length. In <u>tugs</u> 46 m or more in length, addition stiffening is also to be fitted in the tween decks throughout the panting region. 402. Strengthening of bottom forward The requirements for strengthening of bottom forward detailed in Pt 3, Ch 7, Sec 8 do not apply to <u>tugs</u>. </p>	<p style="text-align: center;"> Amendment <Rules> Pt 7 CONTENTS CHAPTER 9 <u>TUG BOATS</u> 177 CHAPTER 9 <u>TUG BOATS</u> Section 1 General 101. Application 1. The construction and equipment of ships intended to be registered as "<u>Tug boat</u>" are to be in accordance with the requirements in this Chapter. The construction and equipment of ships intended to be registered as "Offshore Tug/Supply Ships" are to be in accordance with the requirements of Ch 8. Section 4 Panting and Strengthening of Bottom Forward 401. Panting region reinforcement The arrangements to resist panting required by Pt 3, Ch 9 do not apply to <u>tug boats</u> less than 46 m in length. In <u>tug boats</u> 46 m or more in length, addition stiffening is also to be fitted in the tween decks throughout the panting region. 402. Strengthening of bottom forward The requirements for strengthening of bottom forward detailed in Pt 3, Ch 7, Sec 8 do not apply to <u>tug boats</u>. </p>	

Present	Amendments	Reason
<p style="text-align: center;">Section 6 Towing Arrangements</p> <p>601. Towing hooks</p> <p>1. Towing hooks or equivalent should normally be 5 to 10 percent of the ship's length abaft amidships, but in no circumstances should they be sited forward of the longitudinal center of gravity of the <u>tug</u> in any anticipated condition of loading. In addition, the towing hook should be located as low as practicable in order to minimize heeling moments arising in normal working conditions.</p> <p style="text-align: center;">Section 8 Towing Winch Emergency Release Systems (2021)</p> <p>801. General</p> <p>2. Purpose</p> <p>The purpose of this section is to provide requirements to prevent the capsize of a <u>tug</u> when in the act of towage as a result of the towline force acting transversely to the <u>tug</u> (in beam direction) as a consequence of an unexpected event (could be loss of propulsion/steering or otherwise), whereby the resulting couple generated by offset and opposing transverse forces (towline force is opposed by thrust or hull resistance force) causes the <u>tug</u> to heel and, ultimately, to capsize. This capsize may be referred to as "girting", "girthing", "girding" or "tripping". See Fig 1 which shows the forces acting during towage operations.</p> <p>804. Test requirements</p> <p>2. Installation trials</p> <p>(1) The full functionality of the emergency release system is to be tested as part of the shipboard commissioning trials to the satisfaction of the surveyor. Testing may be conducted either during a bollard pull test or by applying the towline load against a strong point on the deck of the <u>tug</u> that is certified to the appropriate load.</p>	<p style="text-align: center;">Section 6 Towing Arrangements</p> <p>601. Towing hooks</p> <p>1. Towing hooks or equivalent should normally be 5 to 10 percent of the ship's length abaft amidships, but in no circumstances should they be sited forward of the longitudinal center of gravity of the <u>tug boat</u> in any anticipated condition of loading. In addition, the towing hook should be located as low as practicable in order to minimize heeling moments arising in normal working conditions.</p> <p style="text-align: center;">Section 8 Towing Winch Emergency Release Systems (2021)</p> <p>801. General</p> <p>2. Purpose</p> <p>The purpose of this section is to provide requirements to prevent the capsize of a <u>tug boat</u> when in the act of towage as a result of the towline force acting transversely to the <u>tug boat</u> (in beam direction) as a consequence of an unexpected event (could be loss of propulsion/steering or otherwise), whereby the resulting couple generated by offset and opposing transverse forces (towline force is opposed by thrust or hull resistance force) causes the <u>tug boat</u> to heel and, ultimately, to capsize. This capsize may be referred to as "girting", "girthing", "girding" or "tripping". See Fig 1 which shows the forces acting during towage operations.</p> <p>804. Test requirements</p> <p>2. Installation trials</p> <p>(1) The full functionality of the emergency release system is to be tested as part of the shipboard commissioning trials to the satisfaction of the surveyor. Testing may be conducted either during a bollard pull test or by applying the towline load against a strong point on the deck of the <u>tug boat</u> that is certified to the appropriate load.</p>	

Present	Amendment	Note
<p style="text-align: center;">Present 〈Rules〉 Pt 7</p> <p style="text-align: center;">CHAPTER 4 CONTAINER SHIPS Section 2 Longitudinal Strength</p> <p>201. General</p> <p>2. Symbols and definitions</p> <p>(1) symbols</p> <p><i>L</i> : Rule length (m), as defined in Pt 3, Ch 1, 102.</p> <p><i>B</i> : Moulded breadth (m)</p> <p style="text-align: center;">Section 3 Double Bottoms</p> <p>304. Thickness of inner bottom plating</p> <p>1. The thickness of inner bottom plating is not to be less than that obtained from the following formulae, whichever is the greater :</p> <p>where :</p> <p>d_0 : height of centre girder (m).</p>	<p style="text-align: center;">Amendment 〈Rules〉 Pt 7</p> <p style="text-align: center;">CHAPTER 4 CONTAINER SHIPS Section 2 Longitudinal Strength</p> <p>201. General</p> <p>2. Symbols and definitions</p> <p>(1) symbols</p> <p><i>L</i> : Rule length (m), as defined in Pt 3, Ch 1, 102.</p> <p><i>B</i> : Moulded breadth (m), as defined in Pt 3, Ch 1, 104.</p> <p style="text-align: center;">Section 3 Double Bottoms</p> <p>304. Thickness of inner bottom plating</p> <p>1. The thickness of inner bottom plating is not to be less than that obtained from the following formulae, whichever is the greater :</p> <p>where :</p> <p>d_0 : height of centre girder (mm).</p>	

Present	Amendment	Note
<p style="text-align: center;">Present</p> <p style="text-align: center;"><Guidance> Pt 7</p> <p style="text-align: center;">Annex 7-2 Guidance for the Container Securing Arrangements</p> <p>8. Determination and application of forces</p> <p>Table 6 Ship motions</p> <p>- if $B \geq 60\text{m}$, not to be taken less than $f_r \times 18^\circ$ ($f_r \times 0.314\text{rad}$) (If the B is a <u>median</u> value, θ is determined by linear interpolation)</p> <p>(3) Resultant applied forces for unlashd stack Q_i = wind force in one transverse end</p> $Q_i = \frac{\alpha 7.33 c b V_w^2 \cos(C_{YG}\theta) \times 10^{-4}}{2} \quad (\text{kN})$	<p style="text-align: center;">Amendment</p> <p style="text-align: center;"><Guidance> Pt 7</p> <p style="text-align: center;">Annex 7-2 Guidance for the Container Securing Arrangements</p> <p>8. Determination and application of forces</p> <p>Table 6 Ship motions</p> <p>- if $B \geq 60\text{m}$, not to be taken less than $f_r \times 18^\circ$ ($f_r \times 0.314\text{rad}$) (If the B is a <u>intermediate</u> value, θ is determined by linear interpolation)</p> <p>(3) Resultant applied forces for unlashd stack Q_i = wind force in one transverse end</p> $Q_i = \frac{\alpha 7.33 c b V_w^2 \cos(C_{YG}\theta) \times 10^{-4}}{2} \quad (\text{kN})$	<p style="text-align: center;">Note</p> <p style="text-align: center;">$\theta \rightarrow \theta$</p>

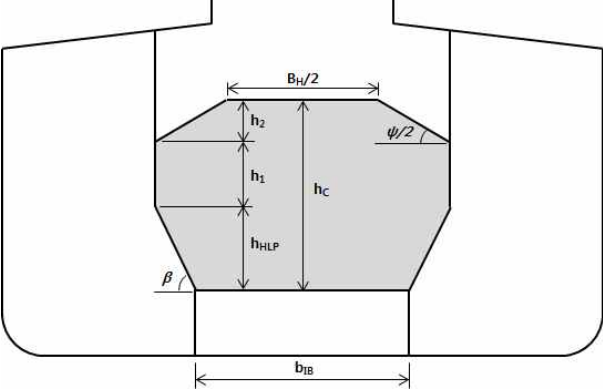
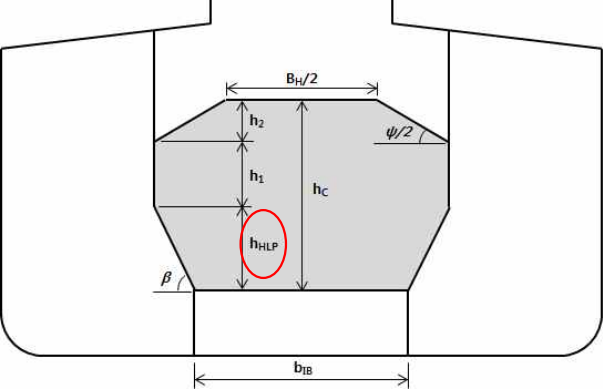
Present	Amendment	Note
<p data-bbox="414 233 658 264">〈Guidance〉 Pt 7</p> <p data-bbox="116 293 958 357">Annex 7-10 Guidance for Direct Strength Assessment for Ore Carriers</p>  <p data-bbox="235 815 837 847">Fig 9 Assumed cargo surface (high density, $h_1 \geq 0$)</p>	<p data-bbox="1323 233 1568 264">〈Guidance〉 Pt 7</p> <p data-bbox="1025 293 1868 357">Annex 7-10 Guidance for Direct Strength Assessment for Ore Carriers</p>  <p data-bbox="1140 815 1742 847">Fig 9 Assumed cargo surface (high density, $h_1 \geq 0$)</p> <p data-bbox="1361 895 1532 927">$h_{HLP} \rightarrow h_{HPL}$</p>	

Present	Amendment	Note
<p style="text-align: center;"> 〈Rules〉 Pt 7 CHAPTER 9 TUGS Section 8 Towing Winch Emergency Release Systems Figure 1 Force during towing Figure 2 Towline 'fleet angle' 〈Guidance〉 Pt 7 CHAPTER 3 BULK CARRIES 702. <u>Figs. 7.3.5 and ~</u> Annex 7-10 Guidance for Direct Strength Assessment for Ore Carriers Figure 15 Transverse distribution of dynamic pressure for BSP-1P(left)와 BSP-1S(right) load cases Figure 16 Transverse distribution of dynamic pressure for BSP-2P(left)와 BSP-2S(right) load cases </p>	<p style="text-align: center;"> 〈Rules〉 Pt 7 CHAPTER 9 TUGS Section 8 Towing Winch Emergency Release Systems Fig 1 Force during towing Fig 2 Towline 'fleet angle' 〈Guidance〉 Pt 7 CHAPTER 3 BULK CARRIES 702. Fig 7.3.5 and ~ Annex 7-10 Guidance for Direct Strength Assessment for Ore Carriers Fig 15 Transverse distribution of dynamic pressure for BSP-1P(left)와 BSP-1S(right) load cases Fig 16 Transverse distribution of dynamic pressure for BSP-2P(left)와 BSP-2S(right) load cases </p>	

Amendment	Note
<p style="text-align: center;">PART 7 Ships of Special Service (Ch1-4, 7-10)</p> <p>Annex 7-6-1 Water Level Detectors on Multiple Hold Cargo Ships other than Bulk Carriers and Tankers (2023)</p> <p>1. Application</p> <p>(1) Multiple hold cargo ships other than bulk carriers and tankers constructed on or after 1 January 2024¹ shall be fitted with water level detectors² in each cargo hold intended for dry cargoes. Water level detectors are not required for cargo holds located entirely above the freeboard deck.</p> <p>(2) The water level detectors required by paragraph (1) shall:</p> <p>(A) give audible and visual alarms at the navigation bridge, one when the water level above the bottom of the cargo hold reaches a height of not less than 0.3 m, and another at a height not less than 15% of the depth of the cargo hold but not more than 2 m; and</p> <p>(B) be fitted at the aft end of the cargo holds. For cargo holds which are occasionally used for water ballast, an alarm overriding device may be installed. The visual alarms shall clearly discriminate between the two different water levels detected in each hold.</p> <p>(3) As an alternative to the water level detector at a height of not less than 0.3 m as per sub-paragraph (2). (A), a bilge level sensor² serving the bilge pumping arrangements required by SOLAS II-1 regulation 35-1 and installed in the cargo hold bilge wells or other suitable location is considered acceptable, subject to:</p> <p>(A) the fitting of the bilge level sensor at a height of not less than 0.3 m at the aft end of the cargo hold; and</p> <p>(B) the bilge level sensor giving audible and visual alarm at the navigation bridge which is clearly distinctive from the alarm given by the other water level detector fitted in the cargo hold.</p> <p>* Footnotes:</p> <p>1. “constructed on or after 1 January 2024” means ships (SOLAS Reg. II-1/1.3.21.1.3.2):</p> <p>.1 for which the building contract is placed on or after 1 January 2024; or</p> <p>.2 in the absence of a building contract, the keel of which is laid or which are at a similar stage of construction on or after 1 July 2024; or</p> <p>.3 the delivery of which is on or after 1 January 2028.</p> <p>2. For the performance standards, installation and testing requirements, Refer to Resolution MSC.188(79)/Rev.2 as may be amended. ⚓</p>	<p>- Correction for reference regulation</p> <p>- Clarification for requirement application</p>

PART 7 (CH5, 6)

Present	Amendment	Note
<p data-bbox="421 220 651 252" style="text-align: center;">⟨Rules⟩ Pt 7-2</p> <p data-bbox="100 288 976 421">Ch 5 Ships Carrying Liquefied Gases in Bulk Section 2 Ship Survival Capability and Location of Cargo Tanks</p> <p data-bbox="91 467 456 496">201. General (IGC Code 2.1)</p> <p data-bbox="123 517 981 759">1. Ships subject to this Chapter shall survive the hydrostatic effects of flooding following assumed hull damage caused by some external force. In addition, to safeguard the ship and the environment, the cargo tanks shall be protected from penetration in the case of minor damage to the ship resulting, for example, from contact with a jetty or <u>tug</u>, and also given a measure of protection from damage in the case of collision or grounding, by locating them at specified minimum distances inboard from the ship's shell plating. ⟨omit⟩</p>	<p data-bbox="1303 220 1588 252" style="text-align: center;">⟨Rules⟩ Pt 7 Ch 5</p> <p data-bbox="1010 288 1886 421">Ch 5 Ships Carrying Liquefied Gases in Bulk Section 2 Ship Survival Capability and Location of Cargo Tanks</p> <p data-bbox="1001 467 1366 496">201. General (IGC Code 2.1)</p> <p data-bbox="1032 517 1888 788">1. Ships subject to this Chapter shall survive the hydrostatic effects of flooding following assumed hull damage caused by some external force. In addition, to safeguard the ship and the environment, the cargo tanks shall be protected from penetration in the case of minor damage to the ship resulting, for example, from contact with a jetty or <u>tug boat</u>, and also given a measure of protection from damage in the case of collision or grounding, by locating them at specified minimum distances inboard from the ship's shell plating. ⟨osame as current⟩</p>	

Present	Amendment	Note
<p style="text-align: center;">〈Rules〉 Pt 7-2</p> <p style="text-align: center;">CHAPTER 5</p> <p>603. 2. (2) <u>Figure</u> 7.5.17, (3) <u>Figure</u> 7.5.18,</p> <p>605. 3. (4) (D) <u>Fig.</u> 7.5.18:</p> <p>804. (84 Page) <u>Fig.</u> 7.5.19</p>	<p style="text-align: center;">〈Rules〉 Pt 7 Ch 5</p> <p style="text-align: center;">CHAPTER 5</p> <p>603. 2. (2) <u>Fig</u> 7.5.17, (3) <u>Fig</u> 7.5.18,</p> <p>605. 3. (4) (D) <u>Fig</u> 7.5.18:</p> <p>804. (84 Page) <u>Fig</u> 7.5.19</p>	
<p style="text-align: center;">〈Guidance〉 Pt 7-2</p> <p style="text-align: center;">CHAPTER 5</p> <p>305. 3. <u>Fig.</u> 7.5.14</p> <p>407. <u>Fig.</u> 7.5.16</p> <p>423. <u>Fig.</u> 7.5.22</p> <p>804. 2 <u>Fig.</u> 7.5.19</p> <p style="text-align: center;">CHAPTER 6</p> <p>701. 3 <u>Fig.</u>7.6.32</p>	<p style="text-align: center;">〈Guidance〉 Pt 7 Ch 5, 6</p> <p style="text-align: center;">CHAPTER 5</p> <p>305. 3. <u>Fig</u> 7.5.14</p> <p>407. <u>Fig</u> 7.5.16</p> <p>423. <u>Fig</u> 7.5.22</p> <p>804. 2 <u>Fig</u> 7.5.19</p> <p style="text-align: center;">CHAPTER 6</p> <p>701. 3 <u>Fig</u> 7.6.32</p>	

PART 9

Present	Amendment	Note
<p style="text-align: center;"><RULE> Part 9 CHAPTER 6 Hull Monitoring Systems</p> <p style="text-align: center;">Section 2 System Requirements</p> <p>202. System Requirements</p> <p>1. Sensors</p> <p>(1) Long based strain gauge</p> <p>(C) The position of the long based strain gauge is to be planned to measure longitudinal hull girder bending stress. The minimum required number and approximate position of the strain gauges are as follows:</p> <p>(b) Container ship :</p> <ul style="list-style-type: none"> - 4 at midship in a ring around the section(two port, two starboard; on deck and upper turn of bilge) - 1 at L/4 from the bow(on deck) 	<p style="text-align: center;"><RULE> Part 9 CHAPTER 6 Hull Monitoring Systems</p> <p style="text-align: center;">Section 2 System Requirements</p> <p>202. System Requirements</p> <p>1. Sensors</p> <p>(1) Long based strain gauge</p> <p>(C) The position of the long based strain gauge is to be planned to measure longitudinal hull girder bending stress. The minimum required number and approximate position of the strain gauges are as follows:</p> <p>(b) Container ship :</p> <ul style="list-style-type: none"> - 4 at midship in a ring around the section(two port, two starboard; on deck and upper turn of bilge) - 1 at L/4 from the bow(on deck) - 1 at L/4 from the stern(on deck) 	<p>- Edited for omission in English version</p>

PART 10

Present	Amendment	Note																																										
<p style="text-align: center;">〈Rules Pt 10〉</p> <p style="text-align: center;">CHAPTER 19 HATCHWAYS AND OTHER DECK OPENINGSS</p> <p style="text-align: center;">Section 1 General</p> <p>104. Corrosion additions</p> <p>The corrosion addition for both sides to be considered for the plating and internal members of hatch covers, hatch coamings and coaming stays is equal to the value specified as follows</p> <table border="1" data-bbox="107 762 965 1174"> <thead> <tr> <th colspan="3" style="text-align: center;">Corrosion addition t_c (mm)</th> </tr> <tr> <th style="text-align: center;">Member</th> <th style="text-align: center;">Bulk carriers Ore carriers Combination carriers</th> <th style="text-align: center;">Others except left column</th> </tr> </thead> <tbody> <tr> <td>Plating and stiffeners of single skin hatch cover</td> <td style="text-align: center;">2.0</td> <td style="text-align: center;">2.0 *</td> </tr> <tr> <td style="text-align: center;">〈omit〉</td> <td style="text-align: center;">2.0</td> <td style="text-align: center;">1.5 *</td> </tr> <tr> <td style="text-align: center;">〈omit〉</td> <td style="text-align: center;">1.5</td> <td style="text-align: center;">1.0</td> </tr> <tr> <td style="text-align: center;">〈omit〉</td> <td style="text-align: center;">1.5</td> <td style="text-align: center;">1.5</td> </tr> <tr> <td colspan="3" style="text-align: center;">〈omit〉</td> </tr> </tbody> </table>	Corrosion addition t_c (mm)			Member	Bulk carriers Ore carriers Combination carriers	Others except left column	Plating and stiffeners of single skin hatch cover	2.0	2.0 *	〈omit〉	2.0	1.5 *	〈omit〉	1.5	1.0	〈omit〉	1.5	1.5	〈omit〉			<p style="text-align: center;">〈Rules Pt 10〉</p> <p style="text-align: center;">CHAPTER 19 HATCHWAYS AND OTHER DECK OPENINGSS</p> <p style="text-align: center;">Section 1 General</p> <p>104. Corrosion additions</p> <p>The corrosion addition for both sides to be considered for the plating and internal members of hatch covers, hatch coamings and coaming stays is equal to the value specified as follows</p> <p>Table 10.19.2 corrosion addition t_c</p> <table border="1" data-bbox="1016 762 1874 1174"> <thead> <tr> <th colspan="3" style="text-align: center;">Corrosion addition t_c (mm)</th> </tr> <tr> <th style="text-align: center;">Member</th> <th style="text-align: center;">Bulk carriers Ore carriers Combination carriers</th> <th style="text-align: center;">Others except left column</th> </tr> </thead> <tbody> <tr> <td>Plating and stiffeners of single skin hatch cover</td> <td style="text-align: center;">2.0</td> <td style="text-align: center;">2.0 *</td> </tr> <tr> <td style="text-align: center;">〈omit〉</td> <td style="text-align: center;">2.0</td> <td style="text-align: center;">1.5 *</td> </tr> <tr> <td style="text-align: center;">〈omit〉</td> <td style="text-align: center;">1.5</td> <td style="text-align: center;">1.0</td> </tr> <tr> <td style="text-align: center;">〈omit〉</td> <td style="text-align: center;">1.5</td> <td style="text-align: center;">1.5</td> </tr> <tr> <td colspan="3" style="text-align: center;">〈omit〉</td> </tr> </tbody> </table>	Corrosion addition t_c (mm)			Member	Bulk carriers Ore carriers Combination carriers	Others except left column	Plating and stiffeners of single skin hatch cover	2.0	2.0 *	〈omit〉	2.0	1.5 *	〈omit〉	1.5	1.0	〈omit〉	1.5	1.5	〈omit〉			<p style="text-align: center;">- 표 제목 누락 반영</p>
Corrosion addition t_c (mm)																																												
Member	Bulk carriers Ore carriers Combination carriers	Others except left column																																										
Plating and stiffeners of single skin hatch cover	2.0	2.0 *																																										
〈omit〉	2.0	1.5 *																																										
〈omit〉	1.5	1.0																																										
〈omit〉	1.5	1.5																																										
〈omit〉																																												
Corrosion addition t_c (mm)																																												
Member	Bulk carriers Ore carriers Combination carriers	Others except left column																																										
Plating and stiffeners of single skin hatch cover	2.0	2.0 *																																										
〈omit〉	2.0	1.5 *																																										
〈omit〉	1.5	1.0																																										
〈omit〉	1.5	1.5																																										
〈omit〉																																												

Present

105. Allowable stresses

The allowable stresses σ_a and τ_a , in N/mm², are to be obtained as follows.

Members of:	σ_a (N/mm ²)	τ_a (N/mm ²)
Weathertight hatch cover	$0.80 \sigma_y$	$0.46 \sigma_y$
Pontoon hatch cover	$0.68 \sigma_y$	$0.39 \sigma_y$
Hatch coaming	$0.95 \sigma_y$	$0.50 \sigma_y$

σ_a : normal Stresses
 τ_a : shear Stresses
 σ_y : yielding Stresses

Section 3 General

304. Primary supporting members

5. Primary supporting members of variable cross-section

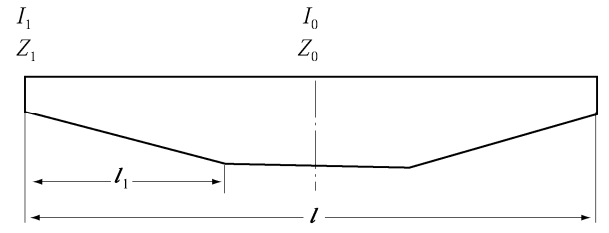

Amendment

105. Allowable stresses

The allowable stresses σ_a and τ_a , in N/mm², are to be obtained as follows.

Table 10.19.3 Allowable stresses σ_a and τ_a

Members of:	σ_a (N/mm ²)	τ_a (N/mm ²)
Weathertight hatch cover	$0.80 \sigma_y$	$0.46 \sigma_y$
Pontoon hatch cover	$0.68 \sigma_y$	$0.39 \sigma_y$
Hatch coaming	$0.95 \sigma_y$	$0.50 \sigma_y$

σ_a : normal Stresses
 τ_a : shear Stresses
 σ_y : yielding Stresses

Section 3 General

304. Primary supporting members

5. Primary supporting members of variable cross-section

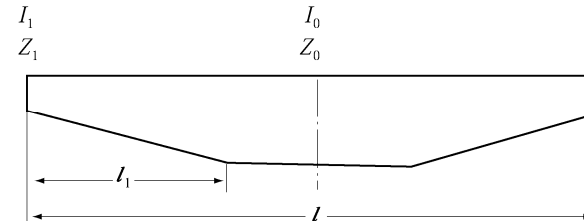

Fig 10.19.1 Primary support member

- 표 제목 누락 반영

PART 14

Present	Amendment	Note
<p style="text-align: center;">〈Rule Pt 14〉</p> <p style="text-align: center;">Chapter 12 Construction</p> <p style="text-align: center;">Section 1 ~ 2 〈omitted〉</p> <p style="text-align: center;">Section 3 Design of Weld Joints</p> <p>1. 〈omitted〉</p> <p>2. Tee or Cross Joint</p> <p>2.1 ~ 2.4 〈omitted〉</p> <p>2.5 Weld size criteria</p> <p>2.5.1 〈omitted〉</p> <p>2.5.2</p> <p>The leg length, ℓ_{leg} in mm, of continuous, lapped or intermittent fillet welds is not to be taken less than the greater of the following values: 〈omitted〉</p> <p>f_{weld} : Weld factor dependent on the type of the structural member, see Table 2, Table 3 and Table 4.</p> <p>〈omitted〉</p>	<p style="text-align: center;">〈Rule Pt 14〉</p> <p style="text-align: center;">Chapter 12 Construction</p> <p style="text-align: center;">Section 1 ~ 2 〈same as the presnt〉</p> <p style="text-align: center;">Section 3 Design of Weld Joints</p> <p>1. 〈same as the presnt〉</p> <p>2. Tee or Cross Joint</p> <p>2.1 ~ 2.4 〈same as the presnt〉</p> <p>2.5 Weld size criteria</p> <p>2.5.1 〈same as the presnt〉</p> <p>2.5.2</p> <p>The leg length, ℓ_{leg} in mm, of continuous, lapped or intermittent fillet welds is not to be taken less than the greater of the following values: 〈same as the presnt〉</p> <p>f_{weld} : Weld factor dependent on the type of the structural member, see Table 2, Table 3 and Table 4.</p> <p>〈same as the presnt〉</p>	

Present			Amendment	Note	
Table 2 : Weld factors for different structural members					
Connection			f_{weld}		
Stiffeners in general	At ends (15% of span) on deep tank bulkheads, brackets at ends		0.30		
	Other span		0.20		
PSM ⁽¹⁾ in general	At ends (15% of span), brackets at ends		0.38		
	Other span		0.24		
	Connection between stiffeners and PSMs, Figure 4 (a)		0.30		
Watertight boundary	Water ballast tanks(Deep tank bulkheads), Figure 4 (b)		0.48		
	Watertight compartments, Other tanks, Figure 4 (b)		0.38		
Deck	Strength deck,	Within 0.6L midship, Figure 4 (a)	PPW ⁽³⁾		
		Elsewhere, Figure 4 (a)	0.48		
	Other deck		0.30		
	Hatch coaming ⁽²⁾	End of hatch corner curvature radius(R.E.) + 100 mm, Figure 5		PPW ⁽³⁾	
		Transverse hatch coaming 15% of hatch coaming height ⁽⁵⁾ , Figure 5		PPW ⁽³⁾ or 0.38	
Elsewhere		PPW ⁽⁴⁾ or 0.38			
Side and bottom structure in double hull	Girder ⁽¹⁾	At ends ⁽⁶⁾ (15% of span), Figure 4 (a)	0.38		
		Center girder	0.30		
		Other girders	0.24		
	Floor, Stringer, Web frame ⁽¹⁾	At ends ⁽⁶⁾ (15% of span), Figure 4 (a)	0.38		
		Other span, Figure 4 (a)	0.24		
Machinery space	Center girder	To keel and inner bottom	0.38		
	Floor	To center girder	0.38		
Fore and Aft part	Above waterline		0.20		
	Below waterline		0.30		
Superstructure, Deckhouse excluding watertight boundary			0.20		
Not specified in the table			0.38		
⁽¹⁾ Weld factor may be determined based on the shear stress according to [2.5.7] ⁽²⁾ $f_{weld} = 0.43$ for hatch coaming other than in cargo holds. ⁽³⁾ PPW : Partial penetration welding in accordance with [2.4.2] . ⁽⁴⁾ PPW : Partial penetration welding in accordance with [2.4.2] , with $f = t_{as-built}/2$ ⁽⁵⁾ Need not to be taken greater than 250 mm ⁽⁶⁾ Need not to be taken greater than length of the shorter side of PSMs					

Present	Amendment			Note																																																																						
	Table 2 : Weld factors for different structural members			- Clarified the application of the welding factor for deep tanks.																																																																						
<table border="1" style="width: 100%; border-collapse: collapse;"> <thead> <tr> <th colspan="2" data-bbox="645 260 1686 300">Connection</th> <th data-bbox="1697 260 1888 300">f_{weld}</th> </tr> </thead> <tbody> <tr> <td data-bbox="645 300 902 363" rowspan="2">Stiffeners in general</td> <td data-bbox="913 300 1686 331">At ends (15% of span) on deep tank bulkheads, brackets at ends</td> <td data-bbox="1697 300 1888 331">0.30</td> </tr> <tr> <td data-bbox="913 331 1686 363">Other span</td> <td data-bbox="1697 331 1888 363">0.20</td> </tr> <tr> <td data-bbox="645 363 902 459" rowspan="3">PSM⁽¹⁾ in general</td> <td data-bbox="913 363 1686 395">At ends (15% of span), brackets at ends</td> <td data-bbox="1697 363 1888 395">0.38</td> </tr> <tr> <td data-bbox="913 395 1686 427">Other span</td> <td data-bbox="1697 395 1888 427">0.24</td> </tr> <tr> <td data-bbox="913 427 1686 459">Connection between stiffeners and PSMs, Figure 4 (a)</td> <td data-bbox="1697 427 1888 459">0.30</td> </tr> <tr> <td data-bbox="645 459 902 523" rowspan="2">Watertight boundary</td> <td data-bbox="913 459 1686 491" style="color: red;">Deep tanks, Figure 4 (b)</td> <td data-bbox="1697 459 1888 491">0.48</td> </tr> <tr> <td data-bbox="913 491 1686 523" style="color: red;">Watertight compartments, Figure 4 (b)</td> <td data-bbox="1697 491 1888 523">0.38</td> </tr> <tr> <td data-bbox="645 523 902 770" rowspan="5">Deck</td> <td data-bbox="913 523 1160 587" rowspan="2">Strength deck,</td> <td data-bbox="1171 523 1686 555">Within 0.6L midship, Figure 4 (a)</td> <td data-bbox="1697 523 1888 555">PPW⁽³⁾</td> </tr> <tr> <td data-bbox="1171 555 1686 587">Elsewhere, Figure 4 (a)</td> <td data-bbox="1697 555 1888 587">0.48</td> </tr> <tr> <td colspan="2" data-bbox="913 587 1686 619">Other deck</td> <td data-bbox="1697 587 1888 619">0.30</td> </tr> <tr> <td data-bbox="913 619 1160 770" rowspan="3">Hatch coaming⁽²⁾</td> <td data-bbox="1171 619 1686 683">End of hatch corner curvature radius(R.E.) + 100 mm, Figure 5</td> <td data-bbox="1697 619 1888 683">PPW⁽³⁾</td> </tr> <tr> <td data-bbox="1171 683 1686 746">Transverse hatch coaming 15% of hatch coaming height⁽⁵⁾, Figure 5</td> <td data-bbox="1697 683 1888 746">PPW⁽³⁾ or 0.38</td> </tr> <tr> <td data-bbox="1171 746 1686 770">Elsewhere</td> <td data-bbox="1697 746 1888 770">PPW⁽⁴⁾ or 0.38</td> </tr> <tr> <td data-bbox="645 770 902 930" rowspan="5">Side and bottom structure in double hull</td> <td data-bbox="913 770 1160 866" rowspan="3">Girder⁽¹⁾</td> <td data-bbox="1171 770 1686 802">At ends⁽⁶⁾ (15% of span), Figure 4 (a)</td> <td data-bbox="1697 770 1888 802">0.38</td> </tr> <tr> <td data-bbox="1171 802 1686 834">Center girder</td> <td data-bbox="1697 802 1888 834">0.30</td> </tr> <tr> <td data-bbox="1171 834 1686 866">Other girders</td> <td data-bbox="1697 834 1888 866">0.24</td> </tr> <tr> <td data-bbox="913 866 1160 930" rowspan="2">Floor, Stringer, Web frame⁽¹⁾</td> <td data-bbox="1171 866 1686 898">At ends⁽⁶⁾ (15% of span), Figure 4 (a)</td> <td data-bbox="1697 866 1888 898">0.38</td> </tr> <tr> <td data-bbox="1171 898 1686 930">Other span, Figure 4 (a)</td> <td data-bbox="1697 898 1888 930">0.24</td> </tr> <tr> <td data-bbox="645 930 902 994" rowspan="2">Machinery space</td> <td data-bbox="913 930 1160 962">Center girder</td> <td data-bbox="1171 930 1686 962">To keel and inner bottom</td> <td data-bbox="1697 930 1888 962">0.38</td> </tr> <tr> <td data-bbox="913 962 1160 994">Floor</td> <td data-bbox="1171 962 1686 994">To center girder</td> <td data-bbox="1697 962 1888 994">0.38</td> </tr> <tr> <td data-bbox="645 994 902 1058" rowspan="2">Fore and Aft part</td> <td colspan="2" data-bbox="913 994 1686 1026">Above waterline</td> <td data-bbox="1697 994 1888 1026">0.20</td> </tr> <tr> <td colspan="2" data-bbox="913 1026 1686 1058">Below waterline</td> <td data-bbox="1697 1026 1888 1058">0.30</td> </tr> <tr> <td colspan="2" data-bbox="645 1058 902 1090">Superstructure, Deckhouse excluding watertight boundary</td> <td data-bbox="1697 1058 1888 1090">0.20</td> </tr> <tr> <td colspan="2" data-bbox="645 1090 902 1121">Not specified in the table</td> <td data-bbox="1697 1090 1888 1121">0.38</td> </tr> <tr> <td colspan="3" data-bbox="645 1121 1888 1321"> <p>⁽¹⁾ Weld factor may be determined based on the shear stress according to [2.5.7]</p> <p>⁽²⁾ $f_{weld} = 0.43$ for hatch coaming other than in cargo holds.</p> <p>⁽³⁾ PPW : Partial penetration welding in accordance with [2.4.2].</p> <p>⁽⁴⁾ PPW : Partial penetration welding in accordance with [2.4.2], with $f = t_{as-built}/2$</p> <p>⁽⁵⁾ Need not to be taken greater than 250 mm</p> <p>⁽⁶⁾ Need not to be taken greater than length of the shorter side of PSMs</p> </td> <td data-bbox="1910 1121 2157 1321"></td> </tr> </tbody> </table>	Connection		f_{weld}		Stiffeners in general	At ends (15% of span) on deep tank bulkheads, brackets at ends	0.30	Other span	0.20	PSM ⁽¹⁾ in general	At ends (15% of span), brackets at ends	0.38	Other span	0.24	Connection between stiffeners and PSMs, Figure 4 (a)	0.30	Watertight boundary	Deep tanks, Figure 4 (b)	0.48	Watertight compartments, Figure 4 (b)	0.38	Deck	Strength deck,	Within 0.6L midship, Figure 4 (a)	PPW ⁽³⁾	Elsewhere, Figure 4 (a)	0.48	Other deck		0.30	Hatch coaming ⁽²⁾	End of hatch corner curvature radius(R.E.) + 100 mm, Figure 5	PPW ⁽³⁾	Transverse hatch coaming 15% of hatch coaming height ⁽⁵⁾ , Figure 5	PPW ⁽³⁾ or 0.38	Elsewhere	PPW ⁽⁴⁾ or 0.38	Side and bottom structure in double hull	Girder ⁽¹⁾	At ends ⁽⁶⁾ (15% of span), Figure 4 (a)	0.38	Center girder	0.30	Other girders	0.24	Floor, Stringer, Web frame ⁽¹⁾	At ends ⁽⁶⁾ (15% of span), Figure 4 (a)	0.38	Other span, Figure 4 (a)	0.24	Machinery space	Center girder	To keel and inner bottom	0.38	Floor	To center girder	0.38	Fore and Aft part	Above waterline		0.20	Below waterline		0.30	Superstructure, Deckhouse excluding watertight boundary		0.20	Not specified in the table		0.38	<p>⁽¹⁾ Weld factor may be determined based on the shear stress according to [2.5.7]</p> <p>⁽²⁾ $f_{weld} = 0.43$ for hatch coaming other than in cargo holds.</p> <p>⁽³⁾ PPW : Partial penetration welding in accordance with [2.4.2].</p> <p>⁽⁴⁾ PPW : Partial penetration welding in accordance with [2.4.2], with $f = t_{as-built}/2$</p> <p>⁽⁵⁾ Need not to be taken greater than 250 mm</p> <p>⁽⁶⁾ Need not to be taken greater than length of the shorter side of PSMs</p>			
Connection		f_{weld}																																																																								
Stiffeners in general	At ends (15% of span) on deep tank bulkheads, brackets at ends	0.30																																																																								
	Other span	0.20																																																																								
PSM ⁽¹⁾ in general	At ends (15% of span), brackets at ends	0.38																																																																								
	Other span	0.24																																																																								
	Connection between stiffeners and PSMs, Figure 4 (a)	0.30																																																																								
Watertight boundary	Deep tanks, Figure 4 (b)	0.48																																																																								
	Watertight compartments, Figure 4 (b)	0.38																																																																								
Deck	Strength deck,	Within 0.6L midship, Figure 4 (a)	PPW ⁽³⁾																																																																							
		Elsewhere, Figure 4 (a)	0.48																																																																							
	Other deck		0.30																																																																							
	Hatch coaming ⁽²⁾	End of hatch corner curvature radius(R.E.) + 100 mm, Figure 5	PPW ⁽³⁾																																																																							
		Transverse hatch coaming 15% of hatch coaming height ⁽⁵⁾ , Figure 5	PPW ⁽³⁾ or 0.38																																																																							
Elsewhere		PPW ⁽⁴⁾ or 0.38																																																																								
Side and bottom structure in double hull	Girder ⁽¹⁾	At ends ⁽⁶⁾ (15% of span), Figure 4 (a)	0.38																																																																							
		Center girder	0.30																																																																							
		Other girders	0.24																																																																							
	Floor, Stringer, Web frame ⁽¹⁾	At ends ⁽⁶⁾ (15% of span), Figure 4 (a)	0.38																																																																							
		Other span, Figure 4 (a)	0.24																																																																							
Machinery space	Center girder	To keel and inner bottom	0.38																																																																							
	Floor	To center girder	0.38																																																																							
Fore and Aft part	Above waterline		0.20																																																																							
	Below waterline		0.30																																																																							
Superstructure, Deckhouse excluding watertight boundary		0.20																																																																								
Not specified in the table		0.38																																																																								
<p>⁽¹⁾ Weld factor may be determined based on the shear stress according to [2.5.7]</p> <p>⁽²⁾ $f_{weld} = 0.43$ for hatch coaming other than in cargo holds.</p> <p>⁽³⁾ PPW : Partial penetration welding in accordance with [2.4.2].</p> <p>⁽⁴⁾ PPW : Partial penetration welding in accordance with [2.4.2], with $f = t_{as-built}/2$</p> <p>⁽⁵⁾ Need not to be taken greater than 250 mm</p> <p>⁽⁶⁾ Need not to be taken greater than length of the shorter side of PSMs</p>																																																																										

PART 15

Present	Correction	Reason
<p style="text-align: center;">〈Part 15〉 Chapter 2 General Arrangement Design Section 4 Compartment Arrangement</p> <p>1. Cofferdam 〈omission〉 2. Double bottom 2.1 ~ 2.2 〈omission〉 2.3 Height of double bottom 2.3.1 Unless otherwise specified, the height of the double bottom is not to be less than the lesser of: $B/20$ or 2 m, however not less than 0.76 m measured vertically from the plane parallel with keel line to inner bottom.</p> <p style="text-align: right;">↓</p>	<p style="text-align: center;">〈Part 15〉 Chapter 2 General Arrangement Design Section 4 Compartment Arrangement</p> <p>1. Cofferdam 〈same as present〉 2. Double bottom 2.1 ~ 2.2 〈same as present〉 2.3 Height of double bottom 2.3.1 Unless otherwise specified, the height of the double bottom is not to be less than the lesser of: $B/15$ or 2 m, however not less than 0.76 m measured vertically from the plane parallel with keel line to inner bottom.</p> <p style="text-align: right;">↓</p>	<p style="text-align: center;">-Typo</p>

OTHER RULES AND GUIDANCE

Present	Amendments	Remarks
<p data-bbox="107 240 954 284">〈Guidance for Approval of Service Suppliers〉</p> <p data-bbox="107 304 954 379">Appendix Part A – Approval of Service Suppliers listed in IACS UR Z17</p> <p data-bbox="125 427 739 456">5. Firms engaged in servicing life saving appliances</p> <p data-bbox="125 504 967 595">5.1 Firms engaged in servicing inflatable liferafts, inflatable lifejackets, hydrostatic release units, marine evacuation systems(Z17 Annex 1–5) (2023)</p> <p data-bbox="159 632 338 660">5.1.1 〈omitted〉</p> <p data-bbox="159 663 506 692">5.1.2 Equipment and facilities IMO Res.A.761(18) as amended by MSC.55(66) gives recommendations on conditions for the approval of servicing stations for inflatable liferafts which shall be observed as relevant. Where inflatable liferafts are subject to extended service intervals, MSC.1/Circ.1328 should also be followed.</p> <p data-bbox="159 874 551 903">5.1.3 Procedures and instructions The Service Supplier shall have documented procedures and instructions for how to carry out service of equipment. Where inflatable liferafts are subject to extended service intervals in accordance with the requirements of SOLAS Reg.III/20.8.3, MSC.1/Circ.1328 should be followed in addition to Res.A.761(18) as amended by MSC.55(66).</p> <p data-bbox="159 1118 338 1147">5.1.4 〈omitted〉</p> <p data-bbox="159 1182 483 1211">5.1.5 Reference Documents The Service Supplier is to have access to the following documents:</p> <p data-bbox="197 1257 967 1377">(1) IMO Res.A.761(18) – Recommendation on Conditions for the Approval of Servicing Stations for Inflatable Liferafts – (adopted on 4 November 1993), amended by Res. MSC.55(66)</p> <p data-bbox="197 1398 499 1426">(2) IMO Res. MSC.55(66)</p> <p data-bbox="197 1445 371 1474">〈newly added〉</p>	<p data-bbox="999 240 1845 284">〈Guidance for Approval of Service Suppliers〉</p> <p data-bbox="999 304 1845 379">Appendix Part A – Approval of Service Suppliers listed in IACS UR Z17</p> <p data-bbox="1016 427 1630 456">5. Firms engaged in servicing life saving appliances</p> <p data-bbox="1016 504 1859 595">5.1 Firms engaged in servicing inflatable liferafts, inflatable lifejackets, hydrostatic release units, marine evacuation systems(Z17 Annex 1–5) (2023)</p> <p data-bbox="1052 632 1496 660">5.1.1 〈same as the current Guidance〉</p> <p data-bbox="1052 663 1400 692">5.1.2 Equipment and facilities IMO Res.A.761(18) as amended by MSC.55(66) <u>and by MSC.388(94)</u> gives recommendations on conditions for the approval of servicing stations for inflatable liferafts which shall be observed as relevant. Where inflatable liferafts are subject to extended service intervals, MSC.1/Circ.1328 should also be followed.</p> <p data-bbox="1052 874 1444 903">5.1.3 Procedures and instructions The Service Supplier shall have documented procedures and instructions for how to carry out service of equipment. Where inflatable liferafts are subject to extended service intervals in accordance with the requirements of SOLAS Reg.III/20.8.3, MSC.1/Circ.1328 should be followed in addition to Res.A.761(18) as amended by MSC.55(66) <u>and by MSC.388(94)</u>.</p> <p data-bbox="1052 1118 1496 1147">5.1.4 〈same as the current Guidance〉</p> <p data-bbox="1052 1182 1377 1211">5.1.5 Reference Documents The Service Supplier is to have access to the following documents:</p> <p data-bbox="1090 1257 1861 1377">(1) IMO Res.A.761(18) – Recommendation on Conditions for the Approval of Servicing Stations for Inflatable Liferafts – (adopted on 4 November 1993), amended by Res. MSC.55(66) <u>and by MSC.388(94)</u></p> <p data-bbox="1090 1398 1393 1426">(2) IMO Res. MSC.55(66)</p> <p data-bbox="1090 1445 1406 1474">(3) IMO Res. MSC.388(94)</p>	<p data-bbox="1883 284 2085 443">- Reflection to IACS UR Z17 (Rev.18 Corr. 1 May 2023)</p> <p data-bbox="1883 632 2141 699">- Reflection to 5.2 of ANNEX I</p> <p data-bbox="1883 842 2141 909">- Reflection to 5.3 of ANNEX I</p> <p data-bbox="1883 1182 2141 1249">- Reflection to 5.5 of ANNEX I</p>

Present	Amendments	Reason
<p style="text-align: center;"> 〈Rules for the Towing Survey of Barges and Tug boats〉 CHAPTER 1 GENERAL Section 1 General </p> <p>101. Application These Rules apply to the <u>tugboats</u> and the barge which are engaged in cargo transportation by towing and to the survey for safe carrying at sea if Owner requests.</p> <p>102. Definitions The definitions specified in these Rules are to be as follows: (1) The <u>tugboats</u> is the ship which is used for towing or pushing (hereinafter called as "towing") the towed ship exclusively. (2) The barge is the ship without propulsion engine and is on-water structures for carrying cargoes at sea to be towed by <u>tugboats</u> generally.</p> <p>103. Restriction in service area</p> <p>1. Restriction in service area for <u>tugboats</u> is to be complied with Korean Ship Safety Act.</p> <p>3. In case of any one of the following conditions, it should not be engaged in cargo transportation in coastal service area and over. (1) <u>tugboats</u> whose length is less than 20 m or whose main engine is smaller than 300 HP</p>	<p style="text-align: center;"> 〈Rules for the Towing Survey of Barges and Tug boats〉 CHAPTER 1 GENERAL Section 1 General </p> <p>101. Application These Rules apply to the <u>tug boats</u> and the barge which are engaged in cargo transportation by towing and to the survey for safe carrying at sea if Owner requests.</p> <p>102. Definitions The definitions specified in these Rules are to be as follows: (1) The <u>tug boats</u> is the ship which is used for towing or pushing (hereinafter called as "towing") the towed ship exclusively. (2) The barge is the ship without propulsion engine and is on-water structures for carrying cargoes at sea to be towed by <u>tug boats</u> generally.</p> <p>103. Restriction in service area</p> <p>1. Restriction in service area for <u>tug boats</u> is to be complied with Korean Ship Safety Act.</p> <p>3. In case of any one of the following conditions, it should not be engaged in cargo transportation in coastal service area and over. (1) <u>tug boats</u> whose length is less than 20 m or whose main engine is smaller than 300 HP</p>	<p>규칙 1편 부록 1-1의 선종부호 15-1.에 따라 tugboat를 tug boat로 수정함 : English only</p>

Present	Amendments	Reason
<p style="text-align: center;">CHAPTER 2 STRUCTURES AND EQUIPMENT</p> <p style="text-align: center;">Section 1 <u>Tugboats</u></p> <p>101. Structure of <u>tugboats</u> Except where specified in this Chapter, structures, scantling, equipment, machinery, electrical equipment, steering gears, etc. of <u>tugboats</u> are to be complied with the Rules and Korean Ship Safety Act or equivalent thereto.</p> <p>102. Stability of <u>tugboats</u> For the <u>tugboats</u> which are larger than 24 m and engaged in greater coastal area, the results of stability calculation are to be approved by the Society except the barge which is smaller than 500 gross tonnage and not engaged in international voyage.</p> <p>103. Communication equipment of <u>tugboats</u> 1. The radio installations required in the Radio Wave Act of Korea in accordance with the requirements of Korean Ship Safety Act. 4. 1. are to be provided in <u>tugboats</u>.</p> <p>104. Life-saving appliances of <u>tugboats</u> Life-saving appliances are to be provided in accordance with the Standard for Ship Life-Saving Appliances on <u>tugboats</u>. And maximum number of persons to be carried on lifeboat or liferaft is to include the expected number of crews on barges.</p> <p>105. Measures for prevention of collision A light, shape, sound and light signal appliances are to be provided in accordance with 1972 COLREG on <u>tugboats</u>.</p> <p>106. Certificate of bollard pull The certificate of bollard pull is to be provided on all <u>tugboats</u>.</p>	<p style="text-align: center;">CHAPTER 2 STRUCTURES AND EQUIPMENT</p> <p style="text-align: center;">Section 1 <u>Tug boats</u></p> <p>101. Structure of <u>tug boats</u> Except where specified in this Chapter, structures, scantling, equipment, machinery, electrical equipment, steering gears, etc. of <u>tugboats</u> are to be complied with the Rules and Korean Ship Safety Act or equivalent thereto.</p> <p>102. Stability of <u>tug boats</u> For the <u>tugboats</u> which are larger than 24 m and engaged in greater coastal area, the results of stability calculation are to be approved by the Society except the barge which is smaller than 500 gross tonnage and not engaged in international voyage.</p> <p>103. Communication equipment of <u>tug boats</u> 1. The radio installations required in the Radio Wave Act of Korea in accordance with the requirements of Korean Ship Safety Act. 4. 1. are to be provided in <u>tug boats</u>.</p> <p>104. Life-saving appliances of <u>tug boats</u> Life-saving appliances are to be provided in accordance with the Standard for Ship Life-Saving Appliances on <u>tug boats</u>. And maximum number of persons to be carried on lifeboat or liferaft is to include the expected number of crews on barges.</p> <p>105. Measures for prevention of collision A light, shape, sound and light signal appliances are to be provided in accordance with 1972 COLREG on <u>tug boats</u>.</p> <p>106. Certificate of bollard pull The certificate of bollard pull is to be provided on all <u>tug boats</u>.</p>	<p>규칙 1편 부록 1-1의 선종부호 15-1.에 따라 tugboat를 tug boat로 수정함 : English only</p>

Present	Amendments	Reason
<p style="text-align: center;">CHAPTER 3 TOWING ARRANGEMENTS</p> <p style="text-align: center;">Section 1 Towing arrangements and resistances</p> <p>101. Towing arrangements (2020) Towing arrangements in <u>tugboats</u> are divided into towing equipment and towing arrangements and specified generally as follows:</p> <p>102. Tow-lines</p> <p>1. The length of tow-lines is determined by the following formula. However, when its service area is restricted within smooth water, it is to be at the discretion of the Society.</p> $S = K(L_1 + L_2)$ <p>S : length of tow-line (m) L_1 : length of <u>tugboats</u> or half length of barge (m) L_2 : length of barge (m) K : the value obtained from following table</p> <p>103. Total resistance of towed ships</p> <p>1. Total resistance of towed ships is to be in accordance with followings and the values may be the requirements for determining the bollard pull of the <u>tugboats</u>.</p>	<p style="text-align: center;">CHAPTER 3 TOWING ARRANGEMENTS</p> <p style="text-align: center;">Section 1 Towing arrangements and resistances</p> <p>101. Towing arrangements (2020) Towing arrangements in <u>tug boats</u> are divided into towing equipment and towing arrangements and specified generally as follows:</p> <p>102. Tow-lines</p> <p>1. The length of tow-lines is determined by the following formula. However, when its service area is restricted within smooth water, it is to be at the discretion of the Society.</p> $S = K(L_1 + L_2)$ <p>S : length of tow-line (m) L_1 : length of <u>tug boats</u> or half length of barge (m) L_2 : length of barge (m) K : the value obtained from following table</p> <p>103. Total resistance of towed ships</p> <p>1. Total resistance of towed ships is to be in accordance with followings and the values may be the requirements for determining the bollard pull of the <u>tug boats</u>.</p>	<p>규칙 1편 부록 1-1의 선종부호 15-1.에 따라 tugboat를 tug boat로 수정함 : English only</p>

Present	Amendments	Reason
<p style="text-align: center;">CHAPTER 4 SURVEY OF TOWINGS</p> <p style="text-align: center;">Section 1 Survey of towing</p> <p>101. Application</p> <p>The requirements in this Chapter apply to the checking of seaworthiness of barges and <u>tugboats</u>, and to the safety inspection of towing arrangement (hereinafter referred to as the “survey of towing”) by Owner’s request before cargo transportation.</p> <p>102. Submission of data</p> <ol style="list-style-type: none"> 1. The Owner is to submit the application for survey of towing and following data to the Society. <ol style="list-style-type: none"> (2) Certificate for bollard pull of <u>tugboats</u> specified in Ch 2. 106 (3) Towing plans including followings <ol style="list-style-type: none"> (A) Main information of <u>tugboats</u> and barges 2. In case of the <u>tugboats</u> and barges holding the certificates of towing approved by the Society already, the data as specified in 1. (1) and (C) and (E) of (3) are to be submitted and the others may be dispensed with. <p>104. Survey of towing</p> <ol style="list-style-type: none"> 1. The survey of towing by <u>tugboats</u> is to be carried out as following: <p>105. Towing Certificates</p> <ol style="list-style-type: none"> 1. Where the <u>tugboats</u>, barges and towing arrangements have undergone the survey to the satisfaction of the Surveyor, the certificate of towing is to be issued. 3. Notwithstanding the requirement in Par 2, the Society may issue the towing certificate with one year validity for <u>tugboats</u> and barges if they are classed with any classification society and intended to sail for specific sailing route periodically provided that: <ol style="list-style-type: none"> (1) the classification of <u>tugboats</u> and barges is to be maintained. 	<p style="text-align: center;">CHAPTER 4 SURVEY OF TOWINGS</p> <p style="text-align: center;">Section 1 Survey of towing</p> <p>101. Application</p> <p>The requirements in this Chapter apply to the checking of seaworthiness of barges and <u>tug boats</u>, and to the safety inspection of towing arrangement (hereinafter referred to as the “survey of towing”) by Owner’s request before cargo transportation.</p> <p>102. Submission of data</p> <ol style="list-style-type: none"> 1. The Owner is to submit the application for survey of towing and following data to the Society. <ol style="list-style-type: none"> (2) Certificate for bollard pull of <u>tug boats</u> specified in Ch 2. 106 (3) Towing plans including followings <ol style="list-style-type: none"> (A) Main information of <u>tug boats</u> and barges 2. In case of the <u>tug boats</u> and barges holding the certificates of towing approved by the Society already, the data as specified in 1. (1) and (C) and (E) of (3) are to be submitted and the others may be dispensed with. <p>104. Survey of towing</p> <ol style="list-style-type: none"> 1. The survey of towing by <u>tug boats</u> is to be carried out as following: <p>105. Towing Certificates</p> <ol style="list-style-type: none"> 1. Where the <u>tug boats</u>, barges and towing arrangements have undergone the survey to the satisfaction of the Surveyor, the certificate of towing is to be issued. 3. Notwithstanding the requirement in Par 2, the Society may issue the towing certificate with one year validity for <u>tug boats</u> and barges if they are classed with any classification society and intended to sail for specific sailing route periodically provided that: <ol style="list-style-type: none"> (1) the classification of <u>tug boats</u> and barges is to be maintained 	<p>규칙 1편 부록 1-1의 선중부호 15-1.에 따라 tugboat를 tug boat로 수정함 : English only</p>

Present	Amendments	Reason
<p style="text-align: center;">〈Ruels for the Classification of Steel Barges〉</p> <p style="text-align: center;">CHAPTER 1 GENERAL</p> <p style="text-align: center;">Section 2 General</p> <p>201. Application [See Guidance]</p> <p>1. The requirements in this rule are applied to steel barges(hereinafter referred to as "barges") generally pulled or pushed by <u>tug</u>, intended to be registered and classed.</p> <p style="text-align: center;">CHAPTER 4 LONGITUDINAL STRENGTH</p> <p style="text-align: center;">Section 2 Bending Strength</p> <p>201. Section modules of hull</p> <p>2. The longitudinal bending moments in still water, M_s, are taken the maximum sagging and hogging moments calculated for all of de-signed loaded and ballast conditions by the method deemed appro-priate by the Society. Furthermore, in a <u>pusher barge</u>, the effect of the joint part is to be considered to the longitudinal bending moment.</p> <p style="text-align: center;">CHAPTER 20 MACHINERY</p> <p style="text-align: center;">Section 4 Auxiliaries and Piping Arrangement</p> <p>407. Bilge systems [See Guidance]</p> <p>13. For unmanned barges, it may not be provided a permanently in-stalled bilge system, however, portable bilge pumping equipment in-cluding hand pumps or acceptable measure(s) for drainage shall be arranged for each compartment(s). The pump(s) or measure(s) can be operated on board the barge or on board the <u>tug</u>. (2023)</p>	<p style="text-align: center;">〈Ruels for the Classification of Steel Barges〉</p> <p style="text-align: center;">CHAPTER 1 GENERAL</p> <p style="text-align: center;">Section 2 General</p> <p>201. Application [See Guidance]</p> <p>1. The requirements in this rule are applied to steel barges(hereinafter referred to as "barges") generally pulled or pushed by <u>a tug boat</u>, in-tended to be registered and classed.</p> <p style="text-align: center;">CHAPTER 4 LONGITUDINAL STRENGTH</p> <p style="text-align: center;">Section 2 Bending Strength</p> <p>201. Section modules of hull</p> <p>2. The longitudinal bending moments in still water, M_s, are taken the maximum sagging and hogging moments calculated for all of de-signed loaded and ballast conditions by the method deemed appro-priate by the Society. Furthermore, in a <u>integrated pusher barge</u>, the effect of the joint part is to be considered to the longitudinal bend-ing moment.</p> <p style="text-align: center;">CHAPTER 20 MACHINERY</p> <p style="text-align: center;">Section 4 Auxiliaries and Piping Arrangement</p> <p>407. Bilge systems [See Guidance]</p> <p>13. For unmanned barges, it may not be provided a permanently in-stalled bilge system, however, portable bilge pumping equipment in-cluding hand pumps or acceptable measure(s) for drainage shall be arranged for each compartment(s). The pump(s) or measure(s) can be operated on board the barge or on board the <u>tug boat</u>. (2023)</p>	<p>규칙 1편 부록 1-1의 선종부호 15-1.에 따 라 tug를 tug boat로 수정함 : English only</p>

Present	Amendments	Reason
<p style="text-align: center;">〈Guidance Relating to the Ruels for the Classification of Steel Barges〉</p> <p style="text-align: center;">CHAPTER 1 GENERAL</p> <p>201. Application 【See Rules】</p> <p>2. The barge intended to be registered as <u>pusher-barge</u> are to be in accordance with the Appendix 1 "Special requirements for <u>pusher-barges</u>".</p> <p style="text-align: center;">ANNEX 1 SPECIAL REQUIREMENTS FOR <u>PUSHER-BARGES</u></p> <p>1. Application</p> <p>(1) The requirements of this Annex apply to the barges intended to be classed as <u>pusher-barges</u> which are barges connected to pusher that are operated by the pushing of pusher.</p> <p>2. Definition</p> <p>(2) Soft connection : Soft connection is a combination method where a barge and pusher is connected to allow relative motion with one or more degree(s) of freedom during a voyage. <u>Pusher-barge</u> connected by this method is to engage in coastal services.</p> <p>3. Longitudinal strength</p> <p>(1) Calculation of longitudinal strength</p> <p>(A) Longitudinal strength of <u>pusher-barge</u> with hard connection is calculated accordance with Ch 4 of the rules using length of connection L_c.</p> <p>(B) Longitudinal strength of <u>pusher-barge</u> with soft connection is calculated accordance with Ch 4 of the rules using length of connection L.</p>	<p style="text-align: center;">〈Guidance Relating to the Ruels for the Classification of Steel Barges〉</p> <p style="text-align: center;">CHAPTER 1 GENERAL</p> <p>201. Application 【See Rules】</p> <p>2. The barge intended to be registered as <u>integrated pusher barges</u> are to be in accordance with the Appendix 1 "Special requirements for <u>integrated pusher barges</u>".</p> <p style="text-align: center;">ANNEX 1 SPECIAL REQUIREMENTS FOR <u>INTEGRATED PUSHER BARGES</u></p> <p>1. Application</p> <p>(1) The requirements of this Annex apply to the barges intended to be classed as <u>integrated pusher barges</u> which are barges connected to pusher that are operated by the pushing of pusher.</p> <p>2. Definition</p> <p>(2) Soft connection : Soft connection is a combination method where a barge and pusher is connected to allow relative motion with one or more degree(s) of freedom during a voyage. <u>Intergrated pusher barge</u> connected by this method is to engage in coastal services.</p> <p>3. Longitudinal strength</p> <p>(1) Calculation of longitudinal strength</p> <p>(A) Longitudinal strength of <u>integrated pusher barges</u> with hard connection is calculated accordance with Ch 4 of the rules using length of connection L_c.</p> <p>(B) Longitudinal strength of <u>integrated pusher barges</u> with soft connection is calculated accordance with Ch 4 of the rules using length of connection L.</p>	<p>규칙 1편 부록 1-1의 선종부호 18. Barge의 특기사항에 언급된 Integrated pusher barge로 수정함 : English only</p>

Present	Amendments	Reason
<p>4. Calculation of scantlings</p> <p>(1) Scantlings of pusher Scantlings of pusher are to comply with the "Rules for the Classification of Steel Ship" using length of pusher only. In case of <u>pusher-barge</u> with hard connection, scantlings of the pusher's hull structure(deck, shell, frame, superstructures, deckhouses, etc.) which will be exposed to wave loading when the pusher is acting as part of the combined unit(pusher + barge) should be designed using L_c. In this case, the scantlings are to be not less than the scantlings complying with the pusher's length only.</p> <p>6. Type of <u>pusher-barges</u> <u>Pusher-barges</u> are classified into two types and are to comply with Table 1.</p> <p>Table 1 Type and Application of <u>Pusher-Barge</u></p> <p>7. Connection structure of <u>pusher-barge</u></p> <p>(1) For the stress assessment of all strength members related with connection of pusher and barge, direct calculation is to be carried out.</p> <p>(A) Where deemed necessary by the Society, the wave hull girder loads and the forces transmitted through the connection are to be calculated from a direct calculation of the <u>pusher-barge</u> combination motion and acceleration in irregular waves, unless such data are available from similar ships.</p> <p>(B) These loads are to be obtained as the most probable that the <u>pusher-barge</u> combination may experience during its operating life for a probability level of 10^{-8}. For this calculation, the wave statistics relevant to the area of navigation and weather condition are to be taken into account.</p>	<p>4. Calculation of scantlings</p> <p>(1) Scantlings of pusher Scantlings of pusher are to comply with the "Rules for the Classification of Steel Ship" using length of pusher only. In case of integrated pusher barge with hard connection, scantlings of the pusher's hull structure(deck, shell, frame, superstructures, deckhouses, etc.) which will be exposed to wave loading when the pusher is acting as part of the combined unit(pusher + barge) should be designed using L_c. In this case, the scantlings are to be not less than the scantlings complying with the pusher's length only.</p> <p>6. Type of integrated pusher barges integrated pusher barges are classified into two types and are to comply with Table 1.</p> <p>Table 1 Type and Application of integrated pusher barge</p> <p>7. Connection structure of integrated pusher barge</p> <p>(1) For the stress assessment of all strength members related with connection of pusher and barge, direct calculation is to be carried out.</p> <p>(A) Where deemed necessary by the Society, the wave hull girder loads and the forces transmitted through the connection are to be calculated from a direct calculation of the integrated pusher barge combination motion and acceleration in irregular waves, unless such data are available from similar ships.</p> <p>(B) These loads are to be obtained as the most probable that the integrated pusher barge combination may experience during its operating life for a probability level of 10^{-8}. For this calculation, the wave statistics relevant to the area of navigation and weather condition are to be taken into account.</p>	<p>규칙 1편 부록 1-1의 선종부호 18. Barge의 특기사항에 언급된 Integrated pusher barge로 수정함 : English only</p>

Present	Amendments	Remarks
<p data-bbox="107 244 958 292"><Guidance for Approval of Service Suppliers></p> <p data-bbox="129 308 936 387">Appendix Part C – Approval of Service Suppliers not listed in IACS UR Z17 (2020)</p> <p data-bbox="129 427 969 491">2. Firms engaged in Visual and/or Sampling Check & Testing for Hazardous Materials(IHM)</p> <p data-bbox="129 507 443 579">2.1 Extent of Engagement <omitted></p> <p data-bbox="129 627 297 659">2.2 Operators</p> <p data-bbox="163 667 969 794">(1) The Supervisor shall be qualified, and licensed as required, according to a recognized national or international industrial standard, for the hazards specified, and have a minimum 2 years' experience on it.</p> <p data-bbox="163 850 969 978">(2) The operators carrying out the sampling/visual check shall be qualified, and licensed as required, according to a recognized national or international industrial standard, for the hazards specified, and have a minimum 1 year experience on it.</p> <p data-bbox="129 1026 499 1106">2.3 Procedures and instructions <omitted></p> <p data-bbox="129 1121 465 1201">2.4 Equipment and Facilities <omitted></p> <p data-bbox="129 1217 521 1289">2.5 Sampling analysis and testing <omitted></p> <p data-bbox="129 1305 309 1377">2.6 Reporting <omitted></p> <p data-bbox="129 1393 309 1473">2.7 Verification <omitted></p>	<p data-bbox="1003 244 1854 292"><Guidance for Approval of Service Suppliers></p> <p data-bbox="1025 308 1832 387">Appendix Part C – Approval of Service Suppliers not listed in IACS UR Z17 (2020)</p> <p data-bbox="1025 427 1865 491">2. Firms engaged in Visual and/or Sampling Check & Testing for Hazardous Materials(IHM)</p> <p data-bbox="1025 507 1417 579">2.1 Extent of Engagement <same as the current omitted></p> <p data-bbox="1025 627 1317 659">2.2 Operators Supervisor</p> <p data-bbox="1059 667 1865 794">(1) The Supervisor shall be qualified, and licensed as required, according to a recognized national or international industrial standard, for the hazards specified, and have a minimum 2 years' experience on it.</p> <p data-bbox="1025 802 1171 834">2.3 Operator</p> <p data-bbox="1059 842 1865 970">(2) (1) The operators carrying out the sampling/visual check shall be qualified, and licensed as required, according to a recognized national or international industrial standard, for the hazards specified, and have a minimum 1 year experience on it.</p> <p data-bbox="1025 1018 1440 1098">2.3 2.4 Procedures and instructions <omitted></p> <p data-bbox="1025 1114 1406 1193">2.4 2.5 Equipment and Facilities <omitted></p> <p data-bbox="1025 1209 1462 1281">2.5 2.6 Sampling analysis and testing <omitted></p> <p data-bbox="1025 1297 1227 1369">2.6 2.7 Reporting <omitted></p> <p data-bbox="1025 1385 1249 1465">2.7 2.8 Verification <omitted></p>	<p data-bbox="1892 292 1982 323">- Typo</p>

Present	Amendment	Reason
<p data-bbox="91 236 931 323"><Rules and Guidance for the Classification of FRP Ships></p> <p data-bbox="147 392 898 432">CHAPTER 1 ~ CHAPTER 3 <Omitted></p> <p data-bbox="282 504 763 544">CHAPTER 4 MOULDING</p> <p data-bbox="371 584 674 616">Section 1 <Omitted></p> <p data-bbox="248 663 797 695">Section 2 Laminating and Moulding</p> <p data-bbox="114 735 383 759">201. ~ 206. <Omitted></p> <p data-bbox="114 775 237 799">207 Repair</p> <p data-bbox="125 823 327 847">1. ~ 2. <Omitted></p> <p data-bbox="114 863 293 887">208. <Omitted></p> <p data-bbox="271 935 775 967">Section 3 ~ Section 8 <Omitted></p> <p data-bbox="147 1046 898 1086">CHAPTER 5 ~ CHAPTER 7 <Omitted></p>	<p data-bbox="987 236 1827 323"><Rules and Guidance for the Classification of FRP Ships></p> <p data-bbox="999 392 1827 472">CHAPTER 1 ~ CHAPTER 3 <Same as the present Rule></p> <p data-bbox="1178 504 1659 544">CHAPTER 4 MOULDING</p> <p data-bbox="1133 584 1704 616">Section 1 <Same as the present Rule></p> <p data-bbox="1144 663 1693 695">Section 2 Laminating and Moulding</p> <p data-bbox="1010 735 1480 759">201. ~ 206. <Same as the present Rule></p> <p data-bbox="1010 775 1133 799">207. Repair</p> <p data-bbox="1021 823 1424 847">1. ~ 2. <Same as the present Rule></p> <p data-bbox="1010 863 1391 887">208. <Same as the present Rule></p> <p data-bbox="1032 935 1805 967">Section 3 ~ Section 8 <Same as the present Rule></p> <p data-bbox="999 1046 1827 1126">CHAPTER 5 ~ CHAPTER 7 <Same as the present Rule></p>	<p data-bbox="1877 767 2007 791">- 서식 통일</p>

Present	Amendment	Reason
<p style="text-align: center;">CHAPTER 8 FRAMES</p> <p style="text-align: center;">Section 1 General</p> <p>101 Application 1. ~ 2. <Omitted></p> <p>102 Frames in Way of Deep Tanks <Omitted></p> <p style="text-align: center;">Section 2 Construction</p> <p>201 Construction of Frames 1. ~ 2. <Omitted></p> <p>202 Cores for Frames 1. ~ 2. <Omitted></p> <p style="text-align: center;">Section 3 Spacing of Frames</p> <p>301 Spacing of Frames 1. ~ 2. <Omitted></p> <p>302 Consideration for Especially Large Frame Spacing <Omitted></p> <p style="text-align: center;">Section 4 Frames</p> <p>401. ~ 402. <Omitted></p> <p>403 Web Frames supporting Side Longitudinals <Omitted></p> <p>404 Hat-type Construction <Omitted></p>	<p style="text-align: center;">CHAPTER 8 FRAMES</p> <p style="text-align: center;">Section 1 General</p> <p>101_ Application 1. ~ 2. <Same as the present Rule></p> <p>102_ Frames in Way of Deep Tanks <Same as the present Rule></p> <p style="text-align: center;">Section 2 Construction</p> <p>201_ Construction of Frames 1. ~ 2. <Same as the present Rule></p> <p>202_ Cores for Frames 1. ~ 2. <Same as the present Rule></p> <p style="text-align: center;">Section 3 Spacing of Frames</p> <p>301_ Spacing of Frames 1. ~ 2. <Same as the present Rule></p> <p>302_ Consideration for Especially Large Frame Spacing <Same as the present Rule></p> <p style="text-align: center;">Section 4 Frames</p> <p>401. ~ 402. <Omitted></p> <p>403_ Web Frames supporting Side Longitudinals <Same as the present Rule></p> <p>404_ Hat-type Construction <Same as the present Rule></p>	<p style="text-align: center;">- 서식 통일</p>

Present	Amendment	Reason
<p>CHAPTER 9 BOTTOM CONSTRUCTION</p> <p>Section 1 ~ Section 5 <Omitted></p> <p>Section 6 Double Bottoms</p> <p>601. ~ 605. <Omitted></p> <p>606 Bottom Longitudinals</p> <p>1. ~ 2. <Omitted></p> <p>Section 7 ~ Section 8 <Omitted></p> <p>CHAPTER 10 ~ CHAPTER 12 <Omitted></p> <p>CHAPTER 13 DEEP TANKS</p> <p>Section 1 <Omitted></p> <p>Section 2 Bulkhead Laminates of Deep Tanks</p> <p>201. ~ 204. <Omitted></p> <p>205 Girders supporting Bulkhead Stiffeners <Omitted></p> <p>206. <Omitted></p> <p>207 Structural Members forming Top and Bottom of Deep Tanks <Omitted></p> <p>Section 3 <Omitted></p>	<p>CHAPTER 9 BOTTOM CONSTRUCTION</p> <p>Section 1 ~ Section 5 <Same as the present Rule></p> <p>Section 6 Double Bottoms</p> <p>601. ~ 605. <Same as the present Rule></p> <p>606_ Bottom Longitudinals</p> <p>1. ~ 2. <Same as the present Rule></p> <p>Section 7 ~ Section 8 <Same as the present Rule></p> <p>CHAPTER 10 ~ CHAPTER 12 <Same as the present Rule></p> <p>CHAPTER 13 DEEP TANKS</p> <p>Section 1 <Same as the present Rule></p> <p>Section 2 Bulkhead Laminates of Deep Tanks</p> <p>201. ~ 204. <Same as the present Rule></p> <p>205_ Girders supporting Bulkhead Stiffeners <Same as the present Rule></p> <p>206. <Same as the present Rule></p> <p>207_ Structural Members forming Top and Bottom of Deep Tanks <Same as the present Rule></p> <p>Section 3 <Same as the present Rule></p>	<p>- 서식 통일</p>

Present	Amendment	Reason
<p>CHAPTER 14 ~ CHAPTER 15 <Omitted></p> <p>CHAPTER 16 HATCHWAY OPENINGS, MACHINERY OPENINGS AND OTHER DECK OPENINGS</p> <p>Section 1 General</p> <p>101 Application <Omitted></p> <p>Section 2 Hatchway Openings</p> <p>201 Height of Hatch Coamings <Omitted></p> <p>202. <Omitted></p> <p>Section 3 Machinery Openings</p> <p>301. ~ 302. <Omitted></p> <p>303 Machinery Casings provided in Enclosed Parts <Omitted></p> <p>304 Position of Fittings <Below Omitted></p>	<p>CHAPTER 14 ~ CHAPTER 15 <Same as the present Rule></p> <p>CHAPTER 16 HATCHWAY OPENINGS, MACHINERY OPENINGS AND OTHER DECK OPENINGS</p> <p>Section 1 General</p> <p>101. Application <Same as the present Rule></p> <p>Section 2 Hatchway Openings</p> <p>201. Height of Hatch Coamings <Same as the present Rule></p> <p>202. <Same as the present Rule></p> <p>Section 3 Machinery Openings</p> <p>301. ~ 302. <Same as the present Rule></p> <p>303. Machinery Casings provided in Enclosed Parts <Same as the present Rule></p> <p>304. Position of Fittings <Below Same as the present Rule></p>	<p>- 서식 통일</p>

Present	Amendment	Reason
<p style="text-align: center;"> 〈Guidance of Heat Transfer Analysis for Ships Carrying Liquefied Gases in Bulk/Ships Using Liquefied Gases as Fuels〉 CHAPTER 2 HEAT TRANSFER ANALYSIS FOR MEMBRANE TYPE Section 1 Analytical Heat Transfer Analysis </p> <p>101. Analysis Procedure</p> <p>1. Procedure of analytical heat transfer analysis</p> <p>(1) The analytical heat transfer analysis is performed according to the flowchart in Figure 2.1.</p> <p>(A) As shown in Figure 2.2, the work to divide the compartment for analytical two-dimensional heat transfer analysis into sections is performed.</p> <p>(B) ~ (H) <Omitted></p> <p>2. <Omitted></p> <p>102. Modeling</p> <p>1. 1-Dimensional heat transfer analysis model</p> <p>(1) The one-dimensional heat transfer analysis model provides the information necessary to understand the analytical heat transfer analysis method and the two-dimensional model is an extension of the one-dimensional model. The one-dimensional heat transfer analysis model is considered as a horizontal and vertical model and an example is shown in Figure 2.3.</p> <p>(2) ~ (5) <Omitted></p> <p>2. ~ 3. <Omitted></p> <p>103. ~ 105. <Omitted></p>	<p style="text-align: center;"> 〈Guidance of Heat Transfer Analysis for Ships Carrying Liquefied Gases in Bulk/Ships Using Liquefied Gases as Fuels〉 CHAPTER 2 HEAT TRANSFER ANALYSIS FOR MEMBRANE TYPE Section 1 Analytical Heat Transfer Analysis </p> <p>101. Analysis Procedure</p> <p>1. Procedure of analytical heat transfer analysis</p> <p>(1) The analytical heat transfer analysis is performed according to the flowchart in Fig 2.1.</p> <p>(A) As shown in Fig 2.2, the work to divide the compartment for analytical two-dimensional heat transfer analysis into sections is performed.</p> <p>(B) ~ (H) <Same as the present Guidance></p> <p>2. <Same as the present Guidance></p> <p>102. Modeling</p> <p>1. 1-Dimensional heat transfer analysis model</p> <p>(1) The one-dimensional heat transfer analysis model provides the information necessary to understand the analytical heat transfer analysis method and the two-dimensional model is an extension of the one-dimensional model. The one-dimensional heat transfer analysis model is considered as a horizontal and vertical model and an example is shown in Fig 2.3.</p> <p>(2) ~ (5) <Same as the present Guidance></p> <p>2. ~ 3. <Same as the present Guidance></p> <p>103. ~ 105. <Same as the present Guidance></p>	<p style="text-align: center;">- 서식 통일</p>

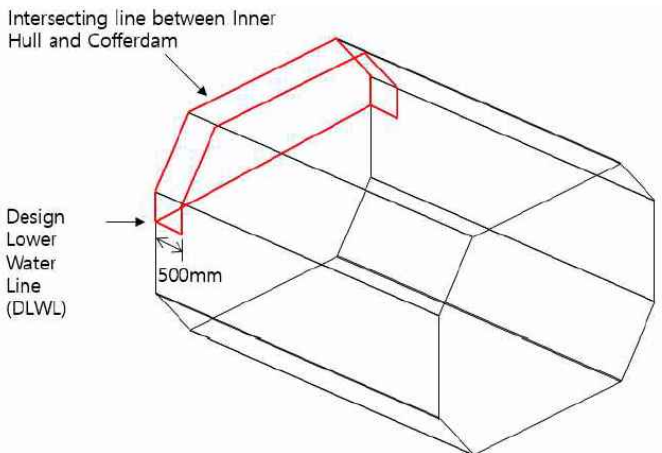
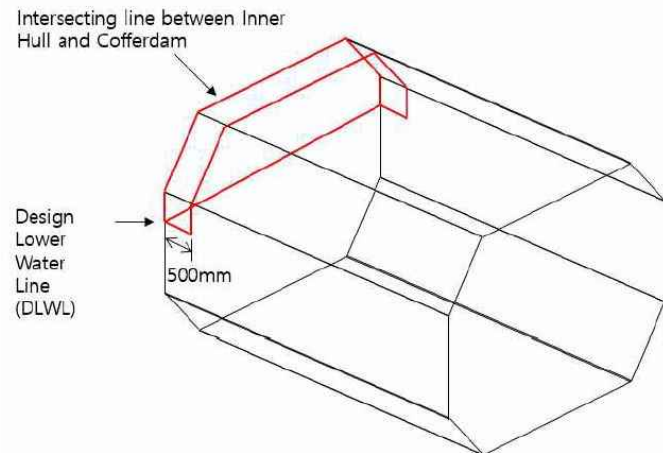
Present	Amendment	Reason
<p style="text-align: center;">Section 2 FEM HEAT TRANSFER ANALYSIS</p> <p>201. ~ 202. <Omitted></p> <p>203. Calculation Conditions</p> <p>1. General</p> <p>(1) <Omitted></p> <p>(2) Convection, radiation and conduction according to the environment of each member should be considered as shown in Figure 2.10 and Table 2.19.</p> <p>(3) <Omitted></p> <p>204. Result Derivation</p> <p>1. General</p> <p>(1) <Omitted></p> <p>2. Selection of steel grade</p> <p>(1) <Omitted></p> <p>(2) As shown in Figure 2.11, <Omitted>.</p>  <p style="text-align: center;">Figure 2.11 Important consideration range in steel selection</p> <p>3. <Omitted></p>	<p style="text-align: center;">Section 2 FEM <u>Heat Transfer Analysis</u></p> <p>201. ~ 202. <Same as the present Guidance></p> <p>203. Calculation Conditions</p> <p>1. General</p> <p>(1) <Same as the present Guidance></p> <p>(2) Convection, radiation and conduction according to the environment of each member should be considered as shown in Fig 2.10 and Table 2.19.</p> <p>(3) <Same as the present Guidance></p> <p>204. Result Derivation</p> <p>1. General</p> <p>(1) <Same as the present Guidance></p> <p>2. Selection of steel grade</p> <p>(1) <Same as the present Guidance></p> <p>(2) As shown in Fig 2.11, <Same as the present Guidance>.</p>  <p style="text-align: center;">Fig 2.11 Important consideration range in steel selection</p> <p>3. <Same as the present Guidance></p>	<p>- 서식 통일</p>

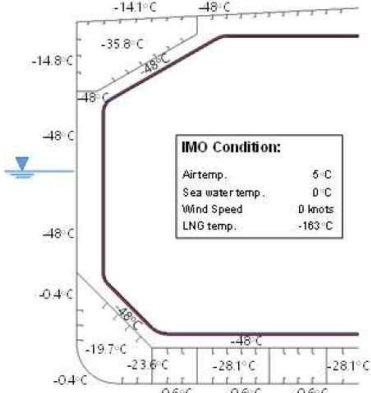
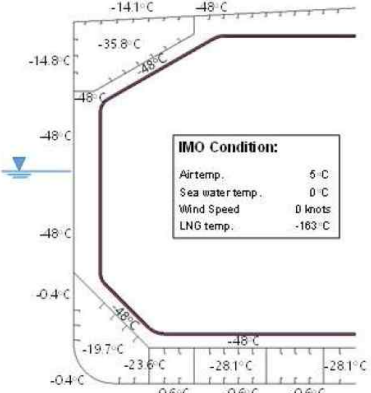
Present	Amendment	Reason
<p data-bbox="120 240 931 316">CHAPTER 3 HEAT TRANSFER ANALYSIS FOR INDEPENDENT TYPE A TANK</p> <p data-bbox="197 357 855 389">Section 1 Analytical Heat Transfer Analysis</p> <p data-bbox="120 432 385 456">101. ~ 104. <Omitted></p> <p data-bbox="120 475 365 499">105. Result Derivation</p> <p data-bbox="129 518 958 616">1. <Omitted> 2. Figure 3.1 illustrates calculation results performed for a midship section of a type A LNG Carrier using analytical method.</p>  <p data-bbox="129 1038 958 1098">Figure 3.1 Temperature calculation for Type A tank using analytical method</p> <p data-bbox="197 1150 855 1182">Section 2 FEM HEAT TRANSFER ANALYSIS</p> <p data-bbox="120 1225 385 1249">201. ~ 203. <Omitted></p> <p data-bbox="120 1268 365 1292">204. Result Derivation</p> <p data-bbox="129 1311 958 1449">1. <Omitted> 2. A sample 2D model of the type A hull for heat transfer analysis is presented in Figure 3.2. 3. As shown 'd' in Figure 3.3, <Omitted></p>	<p data-bbox="1010 240 1821 316">CHAPTER 3 HEAT TRANSFER ANALYSIS FOR INDEPENDENT TYPE A TANK</p> <p data-bbox="1086 357 1744 389">Section 1 Analytical Heat Transfer Analysis</p> <p data-bbox="1010 432 1529 456">101. ~ 104. <Same as the present Guidance></p> <p data-bbox="1010 475 1254 499">105. Result Derivation</p> <p data-bbox="1019 518 1848 616">1. <Same as the present Guidance> 2. Fig 3.1 illustrates calculation results performed for a midship section of a type A LNG Carrier using analytical method.</p>  <p data-bbox="1019 1038 1848 1098">Fig 3.1 Temperature calculation for Type A tank using analytical method</p> <p data-bbox="1131 1150 1704 1182">Section 2 FEM <u>Heat Transfer Analysis</u></p> <p data-bbox="1010 1225 1529 1249">201. ~ 203. <Same as the present Guidance></p> <p data-bbox="1010 1268 1254 1292">204. Result Derivation</p> <p data-bbox="1019 1311 1848 1449">1. <Same as the present Guidance> 2. A sample 2D model of the type A hull for heat transfer analysis is presented in Fig 3.2. 3. As shown 'd' in Fig 3.3, <Same as the present Guidance></p>	<p data-bbox="1877 767 2007 791">- 서식 통일</p>

Present

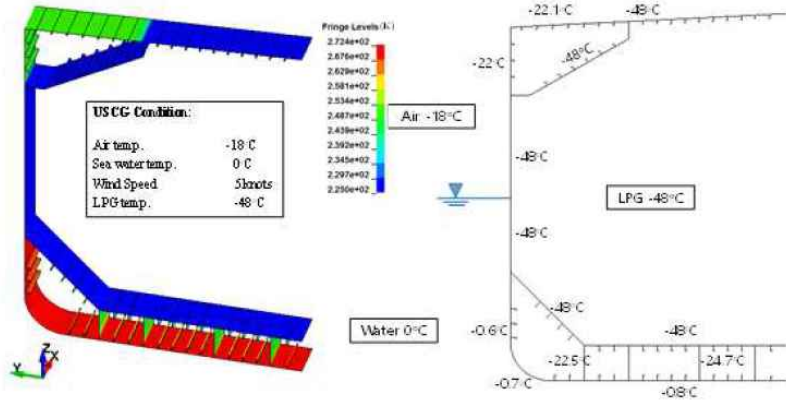

Amendment

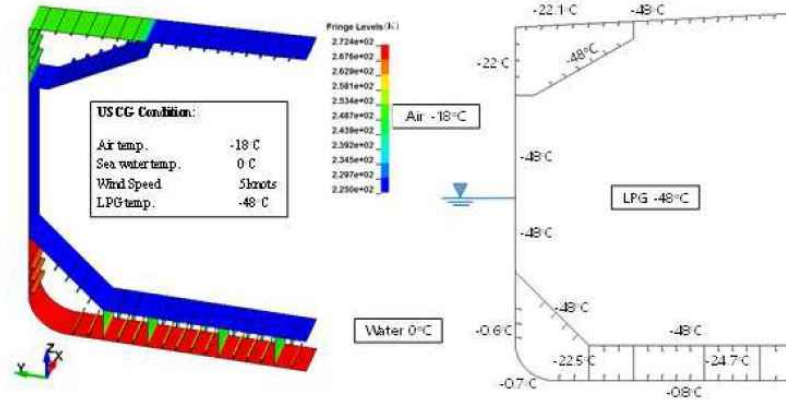

Reason

Figure 3.2 Temperature calculation for type A tank using 2D FEM

Fig 3.2 Temperature calculation for type A tank using 2D FEM

- 서식 통일

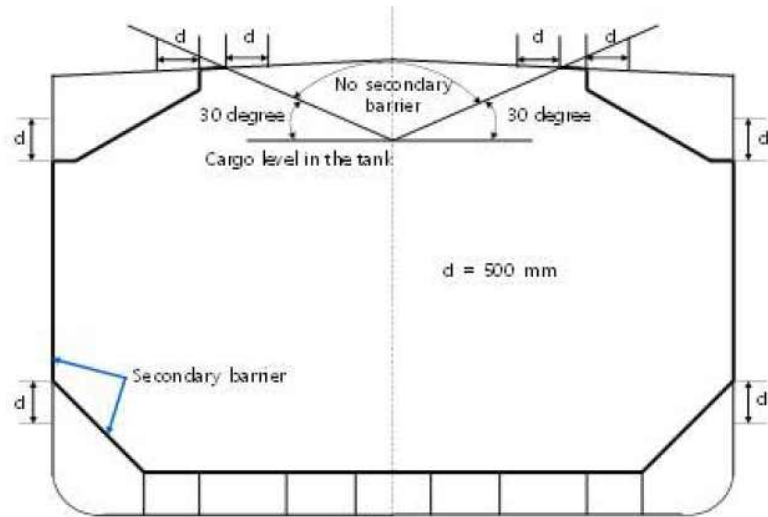
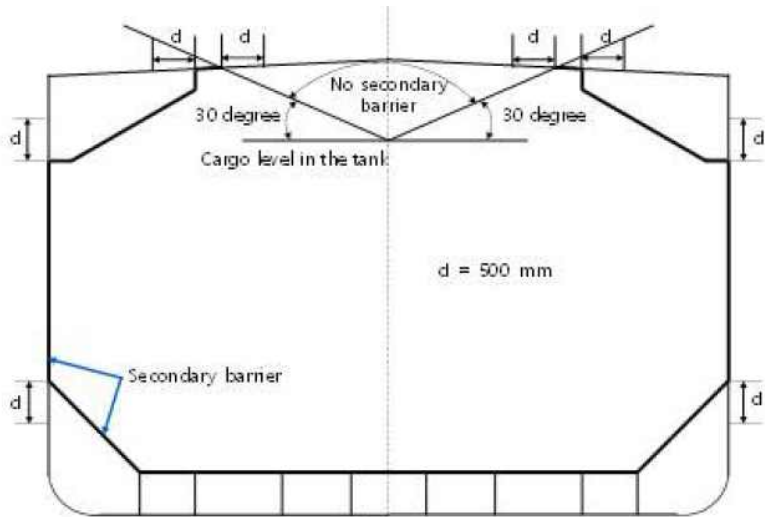

Figure 3.3 Application range extension of secondary steel for type A tank

Fig 3.3 Application range extension of secondary steel for type A tank

Present

Amendment

Reason

CHAPTER 4 HEAT TRANSFER ANALYSIS FOR INDEPENDENT TYPE B TANK

CHAPTER 4 HEAT TRANSFER ANALYSIS FOR INDEPENDENT TYPE B TANK

Section 1 Analytical Heat Transfer Analysis

Section 1 Analytical Heat Transfer Analysis

101. ~ 104. <Omitted>

101. ~ 104. <Same as the present Guidance>

105. Result Derivation

105. Result Derivation

1. <Omitted>

1. <Same as the present Guidance>

2. Figure 4.1 illustrates a temperature calculation results performed for a midship section of a Type B LNG carrier using analytical method.

2. Fig 4.1 illustrates a temperature calculation results performed for a midship section of a Type B LNG carrier using analytical method.

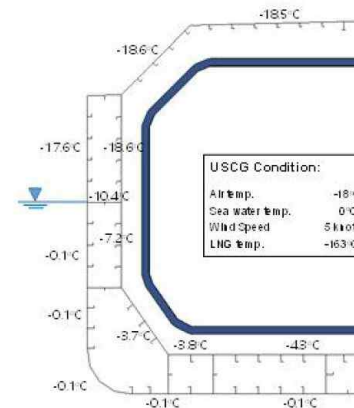
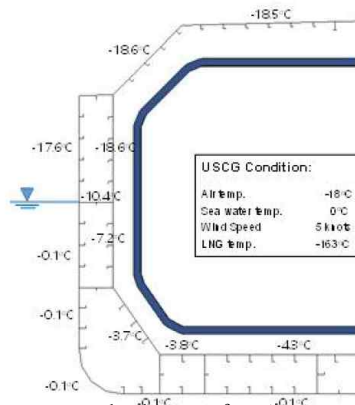

Figure 4.1 Temperature calculation for Type B tank using analytical method

Fig 4.1 Temperature calculation for Type B tank using analytical method

Section 2 FEM ~~HEAT TRANSFER ANALYSIS~~

Section 2 FEM Heat Transfer Analysis

201. ~ 202. <Omitted>

201. ~ 202. <Same as the present Guidance>

203. Calculation Conditions

203. Calculation Conditions

1. <Omitted>

1. <Same as the present Guidance>

2. Figure 4.2 and Table 4.1 presents the application of FEM to modeling of overall heat transfer in the independent type B tank and the required input data for each form of heat energy transfer.

2. Fig 4.2 and Table 4.1 presents the application of FEM to modeling of overall heat transfer in the independent type B tank and the required input data for each form of heat energy transfer.

- 서식 통일

Present

204. Result Derivation

1. <Omitted>
2. Figure 4-3 is one example of temperature analysis result for 2D FEM midship section.
3. Figure 4-4 illustrates a temperature calculation results performed for 3D FEM including cofferdam.

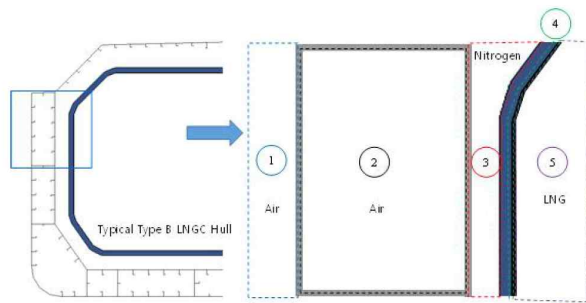

Figure 4.2 Finite element modeling in heat transfer analysis of hull with independent type B tank at Temperature calculation

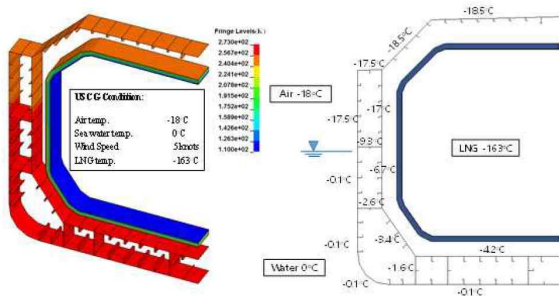

Figure 4-3 Temperature distribution calculation by 2D FEM heat transfer analysis

Amendment

204. Result Derivation

1. <Same as the present Guidance>
2. Fig 4.3 is one example of temperature analysis result for 2D FEM midship section.
3. Fig 4.4 illustrates a temperature calculation results performed for 3D FEM including cofferdam.

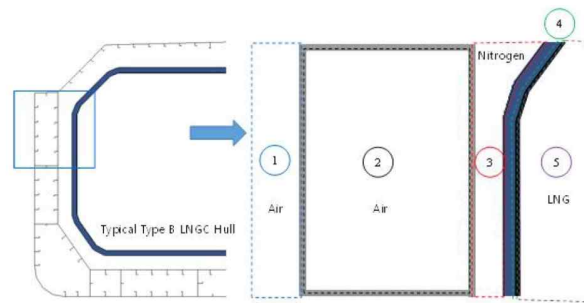

Fig 4.2 Finite element modeling in heat transfer analysis of hull with independent type B tank at Temperature calculation

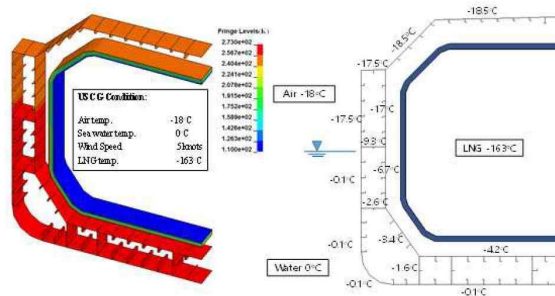

Fig 4.3 Temperature distribution calculation by 2D FEM heat transfer analysis

- 서식 통일

Present

Amendment

Reason

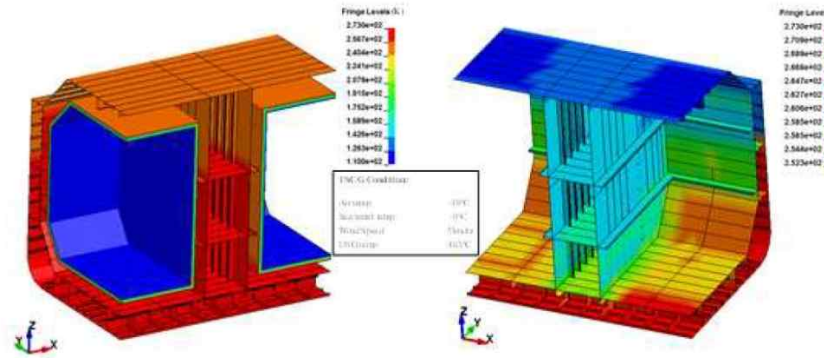
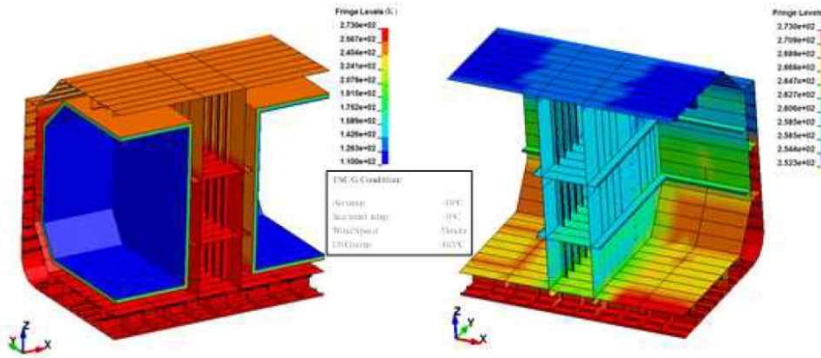

Figure 4-4 Temperature distribution in the cofferdam calculated by 3D FEM heat transfer analysis

Fig 4.4 Temperature distribution in the cofferdam calculated by 3D FEM heat transfer analysis

<Below Omitted>

<Below Same as the present Guidance>

- 서식 통일

Present

<Guidance for Approval of Manufacturing Process and Type Approval, Etc>

CHAPTER 3 TYPE APPROVAL

Section 1 ~ Section 25 <Omitted>

Section 26 Fire Protection Materials

2601. ~ 2603. <Omitted>

2604. Test methods

1. Test method for non-combustible material
<Omitted>

Table 3.26.2 Test method for non-combustible material

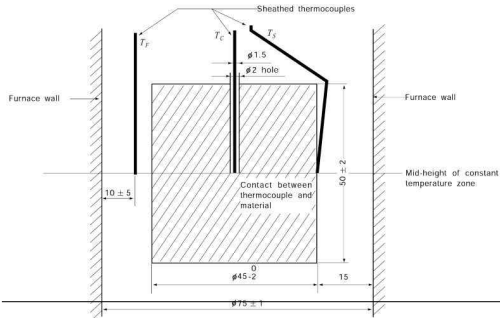
Item	Requirements
Test specimens	<Omitted>
Preparation of specimens	<Omitted>
Conditioning	<Omitted>
Observations during test	(A) ~ (D) <Omitted>  <p>T_F = Furnace thermocouple T_C = Specimen centre thermocouple T_S = Specimen surface thermocouple</p>

Amendment

<Guidance for Approval of Manufacturing Process and Type Approval, Etc>

CHAPTER 3 TYPE APPROVAL

Section 1 ~ Section 25 <Same as the present Guidance>

Section 26 Fire Protection Materials

2601. ~ 2603. <Same as the present Guidance>

2604. Test methods

1. Test method for non-combustible material
<Same as the present Guidance>

Table 3.26.2 Test method for non-combustible material

Item	Requirements
Test specimens	<Same as the present Guidance>
Preparation of specimens	<Same as the present Guidance>
Conditioning	<Same as the present Guidance>
Observations during test	(A) ~ (D) <Same as the present Guidance>
Expression of results	<Same as the present Guidance>
Classification of materials	<Same as the present Guidance>
Others	<Same as the present Guidance>

Reason

- 서식 통일

Present

Expression of results	<Omitted>
Classification of materials	<Omitted>
Others	<Omitted>

<Below Omitted>

Amendment

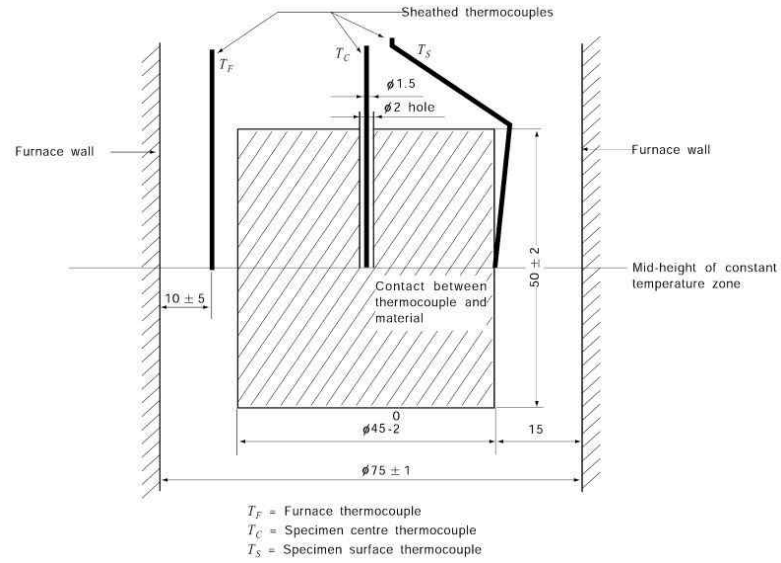

Fig 3.26.1 Relative position of furnace, specimen and thermocouple position

<Below Same as the present Guidance>

Reason

- 서식 통일

Present	Amendment	Note
<p data-bbox="192 245 992 312">Guidances Relating to the Rules for the Classification of Ships Using Low-flashpoint Fuels</p> <p data-bbox="241 341 943 464">Annex 5 Requirements for Ships Using Methyl/Ethyl Alcohol as Fuel (2021)</p> <p data-bbox="430 504 752 539">Section 8 Bunkering</p> <p data-bbox="217 584 331 611">〈Omitted〉</p> <p data-bbox="185 671 360 699">804. Manifold</p> <p data-bbox="250 711 739 738">Ch 5, 401. of this Rules is to be applied.</p> <p data-bbox="185 783 656 810">805. Provisions for bunkering system</p> <ol data-bbox="217 831 999 1171" style="list-style-type: none"> 1. Ch 8, 101. 4 ~ 7 of this Rules is to be applied. 2. In the bunkering line, as close to the connection point as possible, there should be a manually operated stop valve and a remotely operated shutdown valve arranged in series. Alternatively, a combined manually operated and remote shutdown valve may be provided. It should be possible to operate this remotely operated valve from the bunkering control station. 3. For chemical tankers using cargo as fuel, If there is a system that is deemed suitable for its goa and function in this section, the requirements of this section may not apply. <p data-bbox="217 1235 331 1262">〈Omitted〉</p>	<p data-bbox="1030 245 1830 312">Guidances Relating to the Rules for the Classification of Ships Using Low-flashpoint Fuels</p> <p data-bbox="1079 341 1780 464">Annex 5 Requirements for Ships Using Methyl/Ethyl Alcohol as Fuel (2021)</p> <p data-bbox="1267 504 1590 539">Section 8 Bunkering</p> <p data-bbox="1048 584 1162 611">〈Omitted〉</p> <p data-bbox="1019 671 1193 699">804. Manifold</p> <p data-bbox="1081 711 1585 738">Ch 58, 401. of this Rules is to be applied.</p> <p data-bbox="1019 783 1489 810">805. Provisions for bunkering system</p> <ol data-bbox="1050 831 1832 1171" style="list-style-type: none"> 1. Ch 8, 101501. 4 ~ 7 of this Rules is to be applied. 2. In the bunkering line, as close to the connection point as possible, there should be a manually operated stop valve and a remotely operated shutdown valve arranged in series. Alternatively, a combined manually operated and remote shutdown valve may be provided. It should be possible to operate this remotely operated valve from the bunkering control station. 3. For chemical tankers using cargo as fuel, If there is a system that is deemed suitable for its goa and function in this section, the requirements of this section may not apply. <p data-bbox="1048 1235 1162 1262">〈Omitted〉</p>	<p data-bbox="1861 663 2074 767">- Correction for typo error. (Ch 5 → Ch 8)</p> <p data-bbox="1861 887 2074 991">- Correction for typo error. (101. → 501.)</p>

Present	Amendment	Note
<p style="text-align: center;">Annex 5 Requirements for Ships Using Methyl/Ethyl Alcohol as Fuel (2021)</p> <p style="text-align: center;">Section 9 Fuel Supply to Consumer</p> <p>⟨Omitted⟩</p> <p>906. Safety functions of the fuel supply system</p> <ol style="list-style-type: none"> 1. All fuel piping should be arranged for gas-freeing and inerting. 2. Fuel tank inlet and outlet valves should be as close to the tank as possible. Valves required to be operated under normal operation, such as when fuel is supplied to consumers or during bunkering, should be remotely operated if not easily accessible. 3. The main fuel supply line to each consumer or set of consumers should be equipped with an automatically-operated master fuel valve. The master fuel valve(s) should be situated in the part of the piping that is outside the machinery space containing methyl/ethyl alcohol-fuelled consumer(s). The master fuel valve(s) should automatically shut off the fuel supply in accordance with 1502. 3 and table 1. 4. Means of manual emergency shutdown of fuel supply to the consumers or set of consumers should be provided on the primary and secondary escape routes from the consumer compartment, at a location outside consumer space, outside the fuel preparation space and at the bridge. The activation device should be arranged as a physical button, duly marked and protected against inadvertent operation and operable under emergency lighting. <p>⟨Omitted⟩</p>	<p style="text-align: center;">Annex 5 Requirements for Ships Using Methyl/Ethyl Alcohol as Fuel (2021)</p> <p style="text-align: center;">Section 9 Fuel Supply to Consumer</p> <p>⟨Omitted⟩</p> <p>906. Safety functions of the fuel supply system</p> <ol style="list-style-type: none"> 1. All fuel piping should be arranged for gas-freeing and inerting. 2. Fuel tank inlet and outlet valves should be as close to the tank as possible. Valves required to be operated under normal operation, such as when fuel is supplied to consumers or during bunkering, should be remotely operated if not easily accessible. 3. The main fuel supply line to each consumer or set of consumers should be equipped with an automatically-operated master fuel valve. The master fuel valve(s) should be situated in the part of the piping that is outside the machinery space containing methyl/ethyl alcohol-fuelled consumer(s). The master fuel valve(s) should automatically shut off the fuel supply in accordance with 1502. 32 and table 1. 4. Means of manual emergency shutdown of fuel supply to the consumers or set of consumers should be provided on the primary and secondary escape routes from the consumer compartment, at a location outside consumer space, outside the fuel preparation space and at the bridge. The activation device should be arranged as a physical button, duly marked and protected against inadvertent operation and operable under emergency lighting. <p>⟨Omitted⟩</p>	<p>- Correction for typo error. (1502.3 → 1502.2)</p>

Present	Amendment	Note
<p style="text-align: center;">Annex 5 Requirements for Ships Using Methyl/Ethyl Alcohol as Fuel (2021)</p> <p>Section 16 Training, Drills and Emergency Exercises</p> <p>1601. Goal</p> <p>The goal of this Section is to ensure that seafarers on board ships to which this Annex apply, are adequately qualified, trained and experienced.</p> <ol style="list-style-type: none"> 1. Methyl/ethyl alcohol fuel-related drills and exercises should be incorporated into schedule for periodical drills. 2. Ch 16, 101. 2 of this Rules is to be applied. 3. The response and safety system for hazards and accident control should be reviewed and tested. 4. The company should ensure that seafarers on board ships using fuels should have completed training to attain the abilities that are appropriate to the capacity to be filled and duties and responsibilities to be taken up. 5. The master, officers, ratings and other personnel on ships using fuels should be trained and qualified in accordance to the regulation V/3 of the STCW Convention and section A-V/3 of the STCW Code, taking into account the specific hazards of the methyl/ethyl alcohol used as fuel. 	<p style="text-align: center;">Annex 5 Requirements for Ships Using Methyl/Ethyl Alcohol as Fuel (2021)</p> <p>Section 16 Training, Drills and Emergency Exercises</p> <p>1601. Goal</p> <p>The goal of this Section is to ensure that seafarers on board ships to which this Annex apply, are adequately qualified, trained and experienced.</p> <ol style="list-style-type: none"> 1. Methyl/ethyl alcohol fuel-related drills and exercises should be incorporated into schedule for periodical drills. 2. Ch 1617, 101. 2 of this Rules is to be applied. 3. The response and safety system for hazards and accident control should be reviewed and tested. 4. The company should ensure that seafarers on board ships using fuels should have completed training to attain the abilities that are appropriate to the capacity to be filled and duties and responsibilities to be taken up. 5. The master, officers, ratings and other personnel on ships using fuels should be trained and qualified in accordance to the regulation V/3 of the STCW Convention and section A-V/3 of the STCW Code, taking into account the specific hazards of the methyl/ethyl alcohol used as fuel. 	<p>- Correction for typo error. (Ch 16 → Ch 17)</p>

Present	Amendment	Note
<p style="text-align: center;">Annex 5 Requirements for Ships Using Methyl/Ethyl Alcohol as Fuel (2021)</p> <p style="text-align: center;">Section 17 Operation</p> <p>1701. Goal Ch 18, 101. of this Rules is to be applied.</p> <p>1702. Functional requirements Ch 18, 201. of this Rules is to be applied.</p> <p>1703. Maintenance</p> <p>1. Maintenance and repair procedures should include considerations with respect to the fuel containment system and adjacent spaces. Special consideration should be given to the toxicity of fuel.</p> <p>2. Ch 18, 301. 1 of this Rules is to be applied.</p> <p><Omitted></p>	<p style="text-align: center;">Annex 5 Requirements for Ships Using Methyl/Ethyl Alcohol as Fuel (2021)</p> <p style="text-align: center;">Section 17 Operation</p> <p>1701. Goal Ch 18, 101. of this Rules is to be applied.</p> <p>1702. Functional requirements Ch 18, 201. of this Rules is to be applied.</p> <p>1703. Maintenance</p> <p>1. Maintenance and repair procedures should include considerations with respect to the fuel containment system and adjacent spaces. Special consideration should be given to the toxicity of fuel.</p> <p>2. Ch 18, 301. 13 of this Rules is to be applied.</p> <p><Omitted></p>	<p>- Correction for typo error. (Ch 18. 301.1 → Ch 18. 301.3)</p>

Present	Amendment	Note
<p style="text-align: center;">Guidances Relating to the Rules for the Classification of Ships Using Low-flashpoint Fuels</p> <p style="text-align: center;">PART 5 MACHINERY SYSTEM</p> <p style="text-align: center;">CHAPTER 3 PRIME MOVERS, POWER TRANSMISSION SYSTEMS AND LIFT DEVICES, ETC.</p> <p style="text-align: center;">Section 1 General</p> <p>101. Application</p> <p>1. In application to Ch 3, Sec 101, 1 of the Rules, it shall be complied with the requirement of Pt 5, Ch 3, 203 and 204 of Rules for the Classification of Steel Ships.</p> <p>⟨Omitted⟩</p> <p>(2) Propeller shaft and stern tube shaft</p> <p>(B) For propeller shaft and stern tube shaft with corrosion-resistant materials or without effective protection against seawater corrosion it shall be applied to Pt 5, Ch 3, 204 of Guidance for the Classification of Steel Ships.</p> <p>(C) For a ship of 25 m in length and belows, the following formula shall be complied with</p> $d_p = K_s \cdot \sqrt[3]{\frac{P}{n}} \quad (\text{mm})$ <p>P, n : according to Pt 5, Ch 3, 204 of Rules for the Classification of Steel Ships</p> <p>K_s : factor concerning material of shaft is to be complied with the requirement given in Table 5.3.1 of the Guidance</p> <p>(D) For a ship restricted in coastal service, it may be reduced to 95 % of values calculated by (A) or (B) above.</p>	<p style="text-align: center;">Guidances Relating to the Rules for the Classification of Ships Using Low-flashpoint Fuels</p> <p style="text-align: center;">PART 5 MACHINERY SYSTEM</p> <p style="text-align: center;">CHAPTER 3 PRIME MOVERS, POWER TRANSMISSION SYSTEMS AND LIFT DEVICES, ETC.</p> <p style="text-align: center;">Section 1 General</p> <p>101. Application</p> <p>1. In application to Ch 3, Sec 101, 1 of the Rules, it shall be complied with the requirement of Pt 5, Ch 3, 203 and 204 of Rules for the Classification of Steel Ships.</p> <p>⟨Omitted⟩</p> <p>(2) Propeller shaft and stern tube shaft</p> <p>(B) For propeller shaft and stern tube shaft with corrosion-resistant materials or without effective protection against seawater corrosion it shall be applied to Pt 5, Ch 3, 204 of Guidance for the Classification of Steel Ships.</p> <p>(C) For a ship of 25 m in length and belows, the following formula shall be complied with</p> $d_p = K_5 \cdot \sqrt[3]{\frac{P}{n}} \quad (\text{mm})$ <p>P, n : according to Pt 5, Ch 3, 204 of Rules for the Classification of Steel Ships</p> <p>K_5 : factor concerning material of shaft is to be complied with the requirement given in Table 5.3.1 of the Guidance</p> <p>(D) For a ship restricted in coastal service, it may be reduced to 95 % of values calculated by (A) or (B) above.</p>	<p>- Correction for typo error. (K_s → K_5)</p>

Present	Amendment	Note
<p style="text-align: center;"> 〈Guidance for Approval of Manufacturing Process and Type Approval, Etc.〉 CHAPTER 3 TYPE APPROVAL Section 25 Securing Devices </p> <p>2504. Test requirements of additional special feature notation HHS(High Holding Securing) <i>(2021)</i></p> <ol style="list-style-type: none"> 1. 2. 3. <p style="text-align: center;">Fig. 3.25.4</p> <ol style="list-style-type: none"> 4. 5. 6. <p style="text-align: center;">Fig. 3.25.5</p> <ol style="list-style-type: none"> 7. <p>2505. Test requirements of additional special feature notation HHT(High Holding Twistlock) <i>(2021)</i></p> <p>Table 3.25.4 HHS/HHT – Test Loads and Test Modes <i>(2021)</i></p> <p style="text-align: center;">Fig. 3.25.2 Configuration of HHS test equipment (fully automatic twistlock) <i>(2021)</i></p> <p>Table 3.25.5 HHS/HHT – Twistlock function test load <i>(2021)</i></p> <p style="text-align: center;">Fig. 3.25.3 Configuration of HHS test equipment (semi-automatic twistlock) <i>(2021)</i></p>	<p style="text-align: center;"> 〈Guidance for Approval of Manufacturing Process and Type Approval, Etc.〉 CHAPTER 3 TYPE APPROVAL Section 25 Securing Devices </p> <p>2504. Test requirements of additional special feature notation HHS(High Holding Securing) <i>(2021)</i></p> <ol style="list-style-type: none"> 1. 2. 3. 4. 5. 6. 7. <p>Table 3.25.4 HHS/HHT – Test Loads and Test Modes <i>(2021)</i></p> <p style="text-align: center;">Fig. 3.25.2 Configuration of HHS test equipment (fully automatic twistlock) <i>(2021)</i></p> <p>Table 3.25.5 HHS/HHT – Twistlock function test load <i>(2021)</i></p> <p style="text-align: center;">Fig. 3.25.3 Configuration of HHS test equipment (semi-automatic twistlock) <i>(2021)</i></p> <p style="text-align: center;">Fig. 3.25.4</p> <p style="text-align: center;">Fig. 3.25.5</p> <p>2505. Test requirements of additional special feature notation HHT(High Holding Twistlock) <i>(2021)</i></p>	

Present

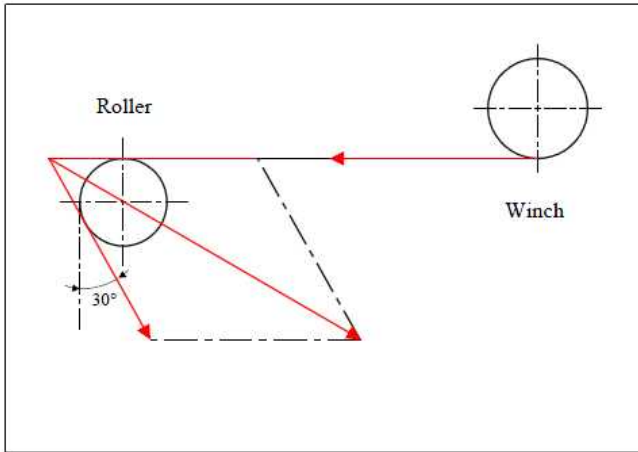

Figure 5.4 Application for Roller Load



Correction

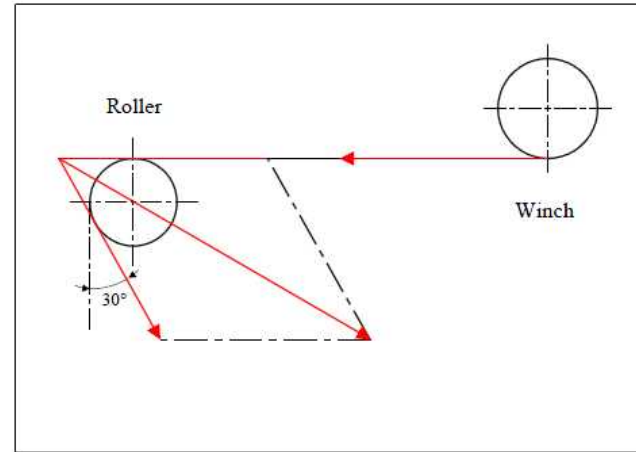

Figure 5.4 Application for Roller Load



Reason

- Typo
: Figure → Fig

Present	Correction	Reason																																																																																												
<p style="text-align: center;"><Guidance for Recreational Crafts></p> <p style="text-align: center;">Section 2 Pressure Adjusting Factors</p> <p>201. ~ 202. <omission></p> <p>203 Dynamic load factor, n_{CG}</p> <p>Table 6.6. Minimum height, $H_{B,min}$, of the cockpit bottom Dimensions in metres</p> <table border="1" data-bbox="107 675 940 914"> <thead> <tr> <th>Design category</th> <th>Height, $H_{B,min}$</th> </tr> </thead> <tbody> <tr> <td>A</td> <td>0.15</td> </tr> <tr> <td>B</td> <td>0.1</td> </tr> <tr> <td>C</td> <td>0.075</td> </tr> <tr> <td>D</td> <td>0.05</td> </tr> </tbody> </table> <p>NOTE Greater heights than these minimum values may be required to fulfil the maximum acceptable draining time according to 305. 2</p> <p>Table 9.2 – Tensile values for connectors</p> <table border="1" data-bbox="107 1098 954 1382"> <thead> <tr> <th>Conductor size mm²</th> <th>Tensile force N</th> <th>Conductor size mm²</th> <th>Tensile force N</th> <th>Conductor size mm²</th> <th>Tensile force N</th> </tr> </thead> <tbody> <tr> <td>0.75</td> <td>40</td> <td>6</td> <td>200</td> <td>50</td> <td>400</td> </tr> <tr> <td>1</td> <td>60</td> <td>10</td> <td>220</td> <td>70</td> <td>440</td> </tr> <tr> <td>1.5</td> <td>130</td> <td>16</td> <td>260</td> <td>95</td> <td>550</td> </tr> <tr> <td>2.5</td> <td>150</td> <td>25</td> <td>310</td> <td>120</td> <td>660</td> </tr> <tr> <td>4</td> <td>170</td> <td>35</td> <td>350</td> <td>150</td> <td>770</td> </tr> </tbody> </table> <p style="text-align: right;">↓</p>	Design category	Height, $H_{B,min}$	A	0.15	B	0.1	C	0.075	D	0.05	Conductor size mm ²	Tensile force N	Conductor size mm ²	Tensile force N	Conductor size mm ²	Tensile force N	0.75	40	6	200	50	400	1	60	10	220	70	440	1.5	130	16	260	95	550	2.5	150	25	310	120	660	4	170	35	350	150	770	<p style="text-align: center;"><Guidance for Recreational Crafts></p> <p style="text-align: center;">Section 2 Pressure Adjusting Factors</p> <p>201. ~ 202. <same as present></p> <p>203. Dynamic load factor, n_{CG}</p> <p>Table 6.6. Minimum height, $H_{B,min}$, of the cockpit bottom Dimensions in metres</p> <table border="1" data-bbox="999 675 1832 914"> <thead> <tr> <th>Design category</th> <th>Height, $H_{B,min}$</th> </tr> </thead> <tbody> <tr> <td>A</td> <td>0.15</td> </tr> <tr> <td>B</td> <td>0.1</td> </tr> <tr> <td>C</td> <td>0.075</td> </tr> <tr> <td>D</td> <td>0.05</td> </tr> </tbody> </table> <p>NOTE Greater heights than these minimum values may be required to fulfil the maximum acceptable draining time according to 305. 2</p> <p>Table 9.2 – Tensile values for connectors</p> <table border="1" data-bbox="999 1098 1845 1382"> <thead> <tr> <th>Conductor size mm²</th> <th>Tensile force N</th> <th>Conductor size mm²</th> <th>Tensile force N</th> <th>Conductor size mm²</th> <th>Tensile force N</th> </tr> </thead> <tbody> <tr> <td>0.75</td> <td>40</td> <td>6</td> <td>200</td> <td>50</td> <td>400</td> </tr> <tr> <td>1</td> <td>60</td> <td>10</td> <td>220</td> <td>70</td> <td>440</td> </tr> <tr> <td>1.5</td> <td>130</td> <td>16</td> <td>260</td> <td>95</td> <td>550</td> </tr> <tr> <td>2.5</td> <td>150</td> <td>25</td> <td>310</td> <td>120</td> <td>660</td> </tr> <tr> <td>4</td> <td>170</td> <td>35</td> <td>350</td> <td>150</td> <td>770</td> </tr> </tbody> </table> <p style="text-align: right;">↓</p>	Design category	Height, $H_{B,min}$	A	0.15	B	0.1	C	0.075	D	0.05	Conductor size mm ²	Tensile force N	Conductor size mm ²	Tensile force N	Conductor size mm ²	Tensile force N	0.75	40	6	200	50	400	1	60	10	220	70	440	1.5	130	16	260	95	550	2.5	150	25	310	120	660	4	170	35	350	150	770	<p>– Typo :add “.”</p> <p>– Typo :delete “.”</p> <p>– Typo :delete “–”</p>
Design category	Height, $H_{B,min}$																																																																																													
A	0.15																																																																																													
B	0.1																																																																																													
C	0.075																																																																																													
D	0.05																																																																																													
Conductor size mm ²	Tensile force N	Conductor size mm ²	Tensile force N	Conductor size mm ²	Tensile force N																																																																																									
0.75	40	6	200	50	400																																																																																									
1	60	10	220	70	440																																																																																									
1.5	130	16	260	95	550																																																																																									
2.5	150	25	310	120	660																																																																																									
4	170	35	350	150	770																																																																																									
Design category	Height, $H_{B,min}$																																																																																													
A	0.15																																																																																													
B	0.1																																																																																													
C	0.075																																																																																													
D	0.05																																																																																													
Conductor size mm ²	Tensile force N	Conductor size mm ²	Tensile force N	Conductor size mm ²	Tensile force N																																																																																									
0.75	40	6	200	50	400																																																																																									
1	60	10	220	70	440																																																																																									
1.5	130	16	260	95	550																																																																																									
2.5	150	25	310	120	660																																																																																									
4	170	35	350	150	770																																																																																									

Present	Correction	Reason
<p style="text-align: center;"><Guidance for Large Yachts></p> <p>CHAPTER 3 HATCHWAYS, WINDOWS AND OTHER OPENINGS</p> <p style="text-align: center;">Section 2 Bulwarks, Freeing Ports, Side Scuttles, Ventilators</p> <p>201. ~ 202. <omission></p> <p>202. Freeing ports</p> <p style="text-align: center;">Section 3 Windows</p> <p>301. Windows <omission></p> <p>303. Deadlights</p> <p style="text-align: center;">CHAPTER 1 FIRE PROTECTION</p> <p style="text-align: center;">Section 1 General</p> <p>101. ~ 103. <omission></p> <p>103. General requirements</p> <p style="text-align: right;">⚓</p>	<p style="text-align: center;"><Guidance for Large Yachts></p> <p>CHAPTER 3 HATCHWAYS, WINDOWS AND OTHER OPENINGS</p> <p style="text-align: center;">Section 2 Bulwarks, Freeing Ports, Side Scuttles, Ventilators</p> <p>201. ~ 202. <same as present></p> <p>2023. Freeing ports</p> <p style="text-align: center;">Section 3 Windows</p> <p>301. Windows <same as present></p> <p>3032. Deadlights</p> <p style="text-align: center;">CHAPTER 1 FIRE PROTECTION</p> <p style="text-align: center;">Section 1 General</p> <p>101. ~ 103. <same as present></p> <p>1034. General requirements</p> <p style="text-align: right;">⚓</p>	<p>-Typo :202=>203</p> <p>-Typo :303=>302</p> <p>-Typo :103=>104</p>

Present	Correction	Reason
<p style="text-align: center;">〈Guidance for Ships for Navigation in Ice〉</p> <p style="text-align: center;">CHAPTER1 STRENGTHENING FOR NAVIGATION IN ICE</p> <p style="text-align: center;">Section 3 Hull Structural Design</p> <p>307. Ice stringers</p> <p>1. Stringer within the ice belt (omission)</p> <p>2. Stringers outside the ice belt</p> <p>The section modulus Z and the effective shear area A of a stringer situated outside the ice belt but supporting ice strengthened frames are not to be less than that obtained from the following formula:</p> $Z = \frac{f_9 f_{10} P_d h l^2}{m \sigma_y} (1 - h_s / l_s) \times 10^6 \text{ (cm}^3\text{)},$ $A = \frac{\sqrt{3} f_9 f_{10} f_{11} P_d h l}{2 \sigma_y} (1 - h_s / l_s) \times 10^4 \text{ (cm}^2\text{)}$ <p>P_d = as specified in 301.1.</p> <p>h = as specified in Table 1.5. However, the product $P_d \times h$ is not to be taken as less than 0.15 MN/m.</p> <p>l = span of the stringer (m).</p> <p>m_s = boundary condition factor as defined in 306.</p> <p>l_s = the distance to the adjacent ice stringer (m).</p> <p>h_s = the shortest distance from the considering stringer to the ice belt (m).</p> <p>f_6 = factor which takes account of load to the transverse frames is to be taken as 0.80.</p> <p>f_{10} = safety factor of stringer ; to be taken as 1.8</p> <p>f_{11} = factor which takes account the maximum shear force versus load location and the shear stress distribution; $f_{11} = 1.2$</p> <p>σ_y = as specified in 302.2.</p>	<p style="text-align: center;">〈Guidance for Ships for Navigation in Ice〉</p> <p style="text-align: center;">CHAPTER1 STRENGTHENING FOR NAVIGATION IN ICE</p> <p style="text-align: center;">Section 3 Hull Structural Design</p> <p>307. Ice stringers</p> <p>1. Stringer within the ice belt (omission)</p> <p>2. Stringers outside the ice belt</p> <p>The section modulus Z and the effective shear area A of a stringer situated outside the ice belt but supporting ice strengthened frames are not to be less than that obtained from the following formula:</p> $Z = \frac{f_9 f_{10} P_d h l^2}{m \sigma_y} (1 - h_s / l_s) \times 10^6 \text{ (cm}^3\text{)},$ $A = \frac{\sqrt{3} f_9 f_{10} f_{11} P_d h l}{2 \sigma_y} (1 - h_s / l_s) \times 10^4 \text{ (cm}^2\text{)}$ <p>P_d = as specified in 301.1.</p> <p>h = as specified in Table 1.5. However, the product $P_d \times h$ is not to be taken as less than 0.15 MN/m.</p> <p>l = span of the stringer (m).</p> <p>m_s = boundary condition factor as defined in 306.</p> <p>l_s = the distance to the adjacent ice stringer (m).</p> <p>h_s = the shortest distance from the considering stringer to the ice belt (m).</p> <p>f_6 f_9 = factor which takes account of load to the transverse frames is to be taken as 0.80.</p> <p>f_{10} = safety factor of stringer ; to be taken as 1.8</p> <p>f_{11} = factor which takes account the maximum shear force versus load location and the shear stress distribution; $f_{11} = 1.2$</p> <p>σ_y = as specified in 302.2.</p>	<p>-Typo : $f_6 = > f_9$</p>

Present	Correction	Reason
<p>Table 3.11 Application of material classes and grades – Structures exposed at low temperatures</p>		
<p>Structural member category</p>	<p>Material class</p>	
<p>○ SECONDARY: - Deck plating exposed to weather, in general - Side plating above LIWL - Transverse bulkheads above LIWL</p>	<p>Within 0.4L amidships</p> <p>I</p>	<p>Outside 0.4L amidships</p> <p>I</p>
<p>○ PRIMARY: - Strength deck plating [1] - Continuous longitudinal members above strength deck, excluding longitudinal hatch coamings - Longitudinal bulkhead above LIWL - Top wing tank bulkhead above LIWL</p>	<p>II</p>	<p>I</p>
<p>○ SPECIAL: - Sheer strake at strength deck [2] - Stringer plate in strength deck [2] - Deck strake at longitudinal bulkhead [3] - Continuous longitudinal hatch coamings [4]</p>	<p>III</p>	<p>II</p>
<p>○ Shell plating, frame and welded stem/sten of ice strengthening region 1 for Arctic7 class ships</p>	<p>I</p>	<p>I</p>
<p>○ Shell plating, frame and welded stem/sten of ice strengthening region 1 for Arctic8 ~ Arctic9 class ships and Icebreakers</p>	<p>II</p>	<p>II</p>
<p>Notes :</p> <p>[1] Plating at corners of large hatch openings to be specially considered. Class III or grade E, EH32, EH36 and EH40 to be applied in positions where high local stresses may occur.</p> <p>[2] Not to be less than grade E, EH32, EH36 and EH40 within 0.4L amidships in ships with length exceeding 250 m</p> <p>[3] In ships with a breadth exceeding 70 m at least three deck strakes to be class III.</p> <p>[4] Not to be less than grade D, DH32, DH36 and DH40.</p>		
		<p>-Typo :Table 3.11 =>Table 3.10</p>

Present	Correction	Reason																							
	<p>Table 3.110 Application of material classes and grades – Structures exposed at low temperatures</p> <table border="1"> <thead> <tr> <th data-bbox="633 320 1227 411" rowspan="2">Structural member category</th> <th colspan="2" data-bbox="1227 320 1821 363">Material class</th> </tr> <tr> <th data-bbox="1227 363 1523 411">Within 0.4L amidships</th> <th data-bbox="1523 363 1821 411">Outside 0.4L amidships</th> </tr> </thead> <tbody> <tr> <td data-bbox="633 411 1227 555"> ○ SECONDARY: - Deck plating exposed to weather, in general - Side plating above LIWL - Transverse bulkheads above LIWL </td> <td data-bbox="1227 411 1523 555" style="text-align: center;">I</td> <td data-bbox="1523 411 1821 555" style="text-align: center;">I</td> </tr> <tr> <td data-bbox="633 555 1227 786"> ○ PRIMARY: - Strength deck plating [1] - Continuous longitudinal members above strength deck, excluding longitudinal hatch coamings - Longitudinal bulkhead above LIWL - Top wing tank bulkhead above LIWL </td> <td data-bbox="1227 555 1523 786" style="text-align: center;">II</td> <td data-bbox="1523 555 1821 786" style="text-align: center;">I</td> </tr> <tr> <td data-bbox="633 786 1227 959"> ○ SPECIAL: - Sheer strake at strength deck [2] - Stringer plate in strength deck [2] - Deck strake at longitudinal bulkhead [3] - Continuous longitudinal hatch coamings [4] </td> <td data-bbox="1227 786 1523 959" style="text-align: center;">III</td> <td data-bbox="1523 786 1821 959" style="text-align: center;">II</td> </tr> <tr> <td data-bbox="633 959 1227 1066"> ○ Shell plating, frame and welded stem/sten of ice strengthening region 1 for Arctic7 class ships </td> <td data-bbox="1227 959 1523 1066" style="text-align: center;">I</td> <td data-bbox="1523 959 1821 1066" style="text-align: center;">I</td> </tr> <tr> <td data-bbox="633 1066 1227 1173"> ○ Shell plating, frame and welded stem/sten of ice strengthening region 1 for Arctic8 ~ Arctic9 class ships and Icebreakers </td> <td data-bbox="1227 1066 1523 1173" style="text-align: center;">II</td> <td data-bbox="1523 1066 1821 1173" style="text-align: center;">II</td> </tr> <tr> <td colspan="3" data-bbox="633 1173 1821 1406"> Notes : [1] Plating at corners of large hatch openings to be specially considered. Class III or grade E, EH32, EH36 and EH40 to be applied in positions where high local stresses may occur. [2] Not to be less than grade E, EH32, EH36 and EH40 within 0.4L amidships in ships with length exceeding 250 m [3] In ships with a breadth exceeding 70 m at least three deck strakes to be class III. [4] Not to be less than grade D, DH32, DH36 and DH40. </td> </tr> </tbody> </table>	Structural member category	Material class		Within 0.4L amidships	Outside 0.4L amidships	○ SECONDARY: - Deck plating exposed to weather, in general - Side plating above LIWL - Transverse bulkheads above LIWL	I	I	○ PRIMARY: - Strength deck plating [1] - Continuous longitudinal members above strength deck, excluding longitudinal hatch coamings - Longitudinal bulkhead above LIWL - Top wing tank bulkhead above LIWL	II	I	○ SPECIAL: - Sheer strake at strength deck [2] - Stringer plate in strength deck [2] - Deck strake at longitudinal bulkhead [3] - Continuous longitudinal hatch coamings [4]	III	II	○ Shell plating, frame and welded stem/sten of ice strengthening region 1 for Arctic7 class ships	I	I	○ Shell plating, frame and welded stem/sten of ice strengthening region 1 for Arctic8 ~ Arctic9 class ships and Icebreakers	II	II	Notes : [1] Plating at corners of large hatch openings to be specially considered. Class III or grade E, EH32, EH36 and EH40 to be applied in positions where high local stresses may occur. [2] Not to be less than grade E, EH32, EH36 and EH40 within 0.4L amidships in ships with length exceeding 250 m [3] In ships with a breadth exceeding 70 m at least three deck strakes to be class III. [4] Not to be less than grade D, DH32, DH36 and DH40.			<p>-Typo :Table 3.11 =>Table 3.10</p>
Structural member category	Material class																								
	Within 0.4L amidships	Outside 0.4L amidships																							
○ SECONDARY: - Deck plating exposed to weather, in general - Side plating above LIWL - Transverse bulkheads above LIWL	I	I																							
○ PRIMARY: - Strength deck plating [1] - Continuous longitudinal members above strength deck, excluding longitudinal hatch coamings - Longitudinal bulkhead above LIWL - Top wing tank bulkhead above LIWL	II	I																							
○ SPECIAL: - Sheer strake at strength deck [2] - Stringer plate in strength deck [2] - Deck strake at longitudinal bulkhead [3] - Continuous longitudinal hatch coamings [4]	III	II																							
○ Shell plating, frame and welded stem/sten of ice strengthening region 1 for Arctic7 class ships	I	I																							
○ Shell plating, frame and welded stem/sten of ice strengthening region 1 for Arctic8 ~ Arctic9 class ships and Icebreakers	II	II																							
Notes : [1] Plating at corners of large hatch openings to be specially considered. Class III or grade E, EH32, EH36 and EH40 to be applied in positions where high local stresses may occur. [2] Not to be less than grade E, EH32, EH36 and EH40 within 0.4L amidships in ships with length exceeding 250 m [3] In ships with a breadth exceeding 70 m at least three deck strakes to be class III. [4] Not to be less than grade D, DH32, DH36 and DH40.																									

Present									Correction	Reason																																																																																									
<p>Table 3.12 Material grade requirements for classes I, II and III at low temperatures</p> <p style="text-align: center;">Class I</p> <table border="1"> <thead> <tr> <th rowspan="2">Plate thickness in (mm)</th> <th colspan="2">-20/-25 °C</th> <th colspan="2">-26/-35 °C</th> <th colspan="2">-36/-45 °C</th> <th colspan="2">-46/-55 °C</th> </tr> <tr> <th><i>MS</i></th> <th><i>HT</i></th> <th><i>MS</i></th> <th><i>HT</i></th> <th><i>MS</i></th> <th><i>HT</i></th> <th><i>MS</i></th> <th><i>HT</i></th> </tr> </thead> <tbody> <tr> <td>$t \leq 10$</td> <td><i>A</i></td> <td><i>AH</i></td> <td><i>B</i></td> <td><i>AH</i></td> <td><i>D</i></td> <td><i>DH</i></td> <td><i>D</i></td> <td><i>DH</i></td> </tr> <tr> <td>$10 < t \leq 15$</td> <td><i>B</i></td> <td><i>AH</i></td> <td><i>D</i></td> <td><i>DH</i></td> <td><i>D</i></td> <td><i>DH</i></td> <td><i>D</i></td> <td><i>DH</i></td> </tr> <tr> <td>$15 < t \leq 20$</td> <td><i>B</i></td> <td><i>AH</i></td> <td><i>D</i></td> <td><i>DH</i></td> <td><i>D</i></td> <td><i>DH</i></td> <td><i>E</i></td> <td><i>EH</i></td> </tr> <tr> <td>$20 < t \leq 25$</td> <td><i>D</i></td> <td><i>DH</i></td> <td><i>D</i></td> <td><i>DH</i></td> <td><i>D</i></td> <td><i>DH</i></td> <td><i>E</i></td> <td><i>EH</i></td> </tr> <tr> <td>$25 < t \leq 30$</td> <td><i>D</i></td> <td><i>DH</i></td> <td><i>D</i></td> <td><i>DH</i></td> <td><i>E</i></td> <td><i>EH</i></td> <td><i>E</i></td> <td><i>EH</i></td> </tr> <tr> <td>$30 < t \leq 35$</td> <td><i>D</i></td> <td><i>DH</i></td> <td><i>D</i></td> <td><i>DH</i></td> <td><i>E</i></td> <td><i>EH</i></td> <td><i>E</i></td> <td><i>EH</i></td> </tr> <tr> <td>$35 < t \leq 45$</td> <td><i>D</i></td> <td><i>DH</i></td> <td><i>E</i></td> <td><i>EH</i></td> <td><i>E</i></td> <td><i>EH</i></td> <td>-</td> <td><i>FH</i></td> </tr> <tr> <td>$45 < t \leq 50$</td> <td><i>E</i></td> <td><i>EH</i></td> <td><i>E</i></td> <td><i>EH</i></td> <td>-</td> <td><i>FH</i></td> <td>-</td> <td><i>FH</i></td> </tr> </tbody> </table>									Plate thickness in (mm)	-20/-25 °C		-26/-35 °C		-36/-45 °C		-46/-55 °C		<i>MS</i>	<i>HT</i>	<i>MS</i>	<i>HT</i>	<i>MS</i>	<i>HT</i>	<i>MS</i>	<i>HT</i>	$t \leq 10$	<i>A</i>	<i>AH</i>	<i>B</i>	<i>AH</i>	<i>D</i>	<i>DH</i>	<i>D</i>	<i>DH</i>	$10 < t \leq 15$	<i>B</i>	<i>AH</i>	<i>D</i>	<i>DH</i>	<i>D</i>	<i>DH</i>	<i>D</i>	<i>DH</i>	$15 < t \leq 20$	<i>B</i>	<i>AH</i>	<i>D</i>	<i>DH</i>	<i>D</i>	<i>DH</i>	<i>E</i>	<i>EH</i>	$20 < t \leq 25$	<i>D</i>	<i>DH</i>	<i>D</i>	<i>DH</i>	<i>D</i>	<i>DH</i>	<i>E</i>	<i>EH</i>	$25 < t \leq 30$	<i>D</i>	<i>DH</i>	<i>D</i>	<i>DH</i>	<i>E</i>	<i>EH</i>	<i>E</i>	<i>EH</i>	$30 < t \leq 35$	<i>D</i>	<i>DH</i>	<i>D</i>	<i>DH</i>	<i>E</i>	<i>EH</i>	<i>E</i>	<i>EH</i>	$35 < t \leq 45$	<i>D</i>	<i>DH</i>	<i>E</i>	<i>EH</i>	<i>E</i>	<i>EH</i>	-	<i>FH</i>	$45 < t \leq 50$	<i>E</i>	<i>EH</i>	<i>E</i>	<i>EH</i>	-	<i>FH</i>	-	<i>FH</i>		<p>-Typo :Table 3.12 =>Table 3.11</p>
Plate thickness in (mm)	-20/-25 °C		-26/-35 °C		-36/-45 °C		-46/-55 °C																																																																																												
	<i>MS</i>	<i>HT</i>	<i>MS</i>	<i>HT</i>	<i>MS</i>	<i>HT</i>	<i>MS</i>	<i>HT</i>																																																																																											
$t \leq 10$	<i>A</i>	<i>AH</i>	<i>B</i>	<i>AH</i>	<i>D</i>	<i>DH</i>	<i>D</i>	<i>DH</i>																																																																																											
$10 < t \leq 15$	<i>B</i>	<i>AH</i>	<i>D</i>	<i>DH</i>	<i>D</i>	<i>DH</i>	<i>D</i>	<i>DH</i>																																																																																											
$15 < t \leq 20$	<i>B</i>	<i>AH</i>	<i>D</i>	<i>DH</i>	<i>D</i>	<i>DH</i>	<i>E</i>	<i>EH</i>																																																																																											
$20 < t \leq 25$	<i>D</i>	<i>DH</i>	<i>D</i>	<i>DH</i>	<i>D</i>	<i>DH</i>	<i>E</i>	<i>EH</i>																																																																																											
$25 < t \leq 30$	<i>D</i>	<i>DH</i>	<i>D</i>	<i>DH</i>	<i>E</i>	<i>EH</i>	<i>E</i>	<i>EH</i>																																																																																											
$30 < t \leq 35$	<i>D</i>	<i>DH</i>	<i>D</i>	<i>DH</i>	<i>E</i>	<i>EH</i>	<i>E</i>	<i>EH</i>																																																																																											
$35 < t \leq 45$	<i>D</i>	<i>DH</i>	<i>E</i>	<i>EH</i>	<i>E</i>	<i>EH</i>	-	<i>FH</i>																																																																																											
$45 < t \leq 50$	<i>E</i>	<i>EH</i>	<i>E</i>	<i>EH</i>	-	<i>FH</i>	-	<i>FH</i>																																																																																											

Present

Correction

Reason

Table 3.121 Material grade requirements for classes I, II and III at low temperatures

Class I

Plate thickness in (mm)	-20/-25 °C		-26/-35 °C		-36/-45 °C		-46/-55 °C	
	<i>MS</i>	<i>HT</i>	<i>MS</i>	<i>HT</i>	<i>MS</i>	<i>HT</i>	<i>MS</i>	<i>HT</i>
$t \leq 10$	<i>A</i>	<i>AH</i>	<i>B</i>	<i>AH</i>	<i>D</i>	<i>DH</i>	<i>D</i>	<i>DH</i>
$10 < t \leq 15$	<i>B</i>	<i>AH</i>	<i>D</i>	<i>DH</i>	<i>D</i>	<i>DH</i>	<i>D</i>	<i>DH</i>
$15 < t \leq 20$	<i>B</i>	<i>AH</i>	<i>D</i>	<i>DH</i>	<i>D</i>	<i>DH</i>	<i>E</i>	<i>EH</i>
$20 < t \leq 25$	<i>D</i>	<i>DH</i>	<i>D</i>	<i>DH</i>	<i>D</i>	<i>DH</i>	<i>E</i>	<i>EH</i>
$25 < t \leq 30$	<i>D</i>	<i>DH</i>	<i>D</i>	<i>DH</i>	<i>E</i>	<i>EH</i>	<i>E</i>	<i>EH</i>
$30 < t \leq 35$	<i>D</i>	<i>DH</i>	<i>D</i>	<i>DH</i>	<i>E</i>	<i>EH</i>	<i>E</i>	<i>EH</i>
$35 < t \leq 45$	<i>D</i>	<i>DH</i>	<i>E</i>	<i>EH</i>	<i>E</i>	<i>EH</i>	-	<i>FH</i>
$45 < t \leq 50$	<i>E</i>	<i>EH</i>	<i>E</i>	<i>EH</i>	-	<i>FH</i>	-	<i>FH</i>

-Typo
:Table 3.12
=>Table 3.11

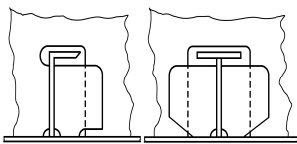
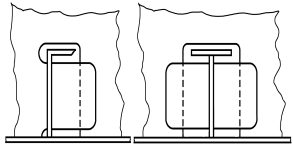
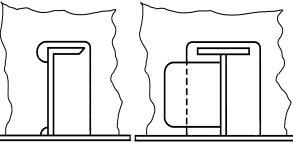
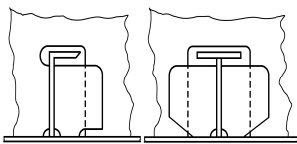
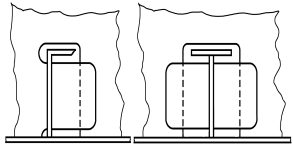
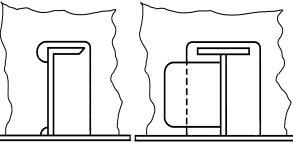
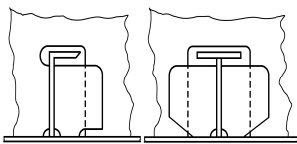
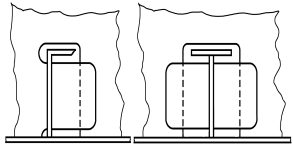
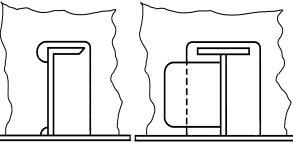
Present			Correction	Reason																														
<p>Table 3.14 The intersections of plate structures with main framing</p> <table border="1"> <thead> <tr> <th rowspan="2">Ship class</th> <th colspan="3">Sketch of structure</th> <th rowspan="2">Other regions as per Table 3.9</th> </tr> <tr> <th></th> <th></th> <th></th> </tr> </thead> <tbody> <tr> <td>Icebreaker5, Icebreaker6</td> <td>Fore peak, after peak, region 1, 2 with longitudinal framing</td> <td>Regions 2, A3, B3, D3, A4, B4</td> <td></td> </tr> <tr> <td>Icebreaker3, Icebreaker4</td> <td>Fore peak, after peak, region 1, 2 with longitudinal framing</td> <td>Regions 1 and 2 (except fore peak and after peak) A3, B3, D3</td> <td></td> </tr> <tr> <td>Arctic7 ~ Arctic9</td> <td>Fore peak, region 1 with longitudinal framing</td> <td>Regions 1 and 2 (except fore peak), A3, A4, B3, B4</td> <td></td> </tr> <tr> <td>Arctic5, Arctic6</td> <td>Fore peak, region A1, B1, C1 with longitudinal framing</td> <td>Regions 1 (except fore peak), 2, A3, B3</td> <td></td> </tr> <tr> <td>Arctic4</td> <td>—</td> <td>Regions 1, A2, B2, A3, B3</td> <td></td> </tr> </tbody> </table>					Ship class	Sketch of structure			Other regions as per Table 3.9				Icebreaker5, Icebreaker6	Fore peak, after peak, region 1, 2 with longitudinal framing	Regions 2, A3, B3, D3, A4, B4		Icebreaker3, Icebreaker4	Fore peak, after peak, region 1, 2 with longitudinal framing	Regions 1 and 2 (except fore peak and after peak) A3, B3, D3		Arctic7 ~ Arctic9	Fore peak, region 1 with longitudinal framing	Regions 1 and 2 (except fore peak), A3, A4, B3, B4		Arctic5, Arctic6	Fore peak, region A1, B1, C1 with longitudinal framing	Regions 1 (except fore peak), 2, A3, B3		Arctic4	—	Regions 1, A2, B2, A3, B3			<p>– Typo :Table 3.14 => Table 3.15</p>
Ship class	Sketch of structure			Other regions as per Table 3.9																														
																																		
Icebreaker5, Icebreaker6	Fore peak, after peak, region 1, 2 with longitudinal framing	Regions 2, A3, B3, D3, A4, B4																																
Icebreaker3, Icebreaker4	Fore peak, after peak, region 1, 2 with longitudinal framing	Regions 1 and 2 (except fore peak and after peak) A3, B3, D3																																
Arctic7 ~ Arctic9	Fore peak, region 1 with longitudinal framing	Regions 1 and 2 (except fore peak), A3, A4, B3, B4																																
Arctic5, Arctic6	Fore peak, region A1, B1, C1 with longitudinal framing	Regions 1 (except fore peak), 2, A3, B3																																
Arctic4	—	Regions 1, A2, B2, A3, B3																																

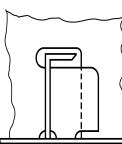
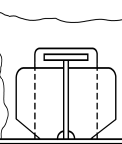
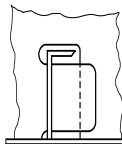
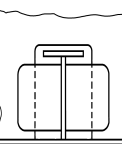
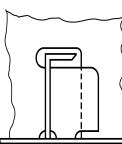
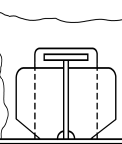
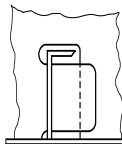
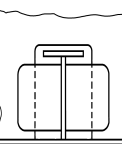
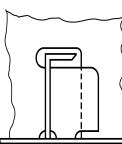
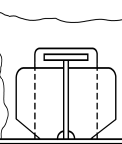
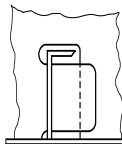
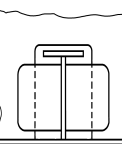
Present	Correction	Reason																										
	<p data-bbox="629 276 1285 304">Table 3.14 The intersections of plate structures with main framing</p> <table border="1" data-bbox="629 311 1841 984"> <thead> <tr> <th data-bbox="629 311 884 523" rowspan="2">Ship class</th> <th colspan="4" data-bbox="884 311 1841 363">Sketch of structure</th> </tr> <tr> <th data-bbox="884 363 1032 523"></th> <th data-bbox="1032 363 1207 523"></th> <th data-bbox="1207 363 1355 523"></th> <th data-bbox="1355 363 1529 523"></th> </tr> </thead> <tbody> <tr> <td data-bbox="629 523 884 625">Icebreaker5, Icebreaker6</td> <td data-bbox="884 523 1032 625">Fore peak, after peak, region 1, 2 with longitudinal framing</td> <td data-bbox="1032 523 1207 625">Regions 2, A3, B3, D3, A4, B4</td> <td colspan="2" data-bbox="1529 523 1841 984" rowspan="5">Other regions as per Table 3.9</td> </tr> <tr> <td data-bbox="629 625 884 727">Icebreaker3, Icebreaker4</td> <td data-bbox="884 625 1032 727">Fore peak, after peak, region 1, 2 with longitudinal framing</td> <td data-bbox="1032 625 1207 727">Regions 1 and 2 (except fore peak and after peak) A3, B3, D3</td> </tr> <tr> <td data-bbox="629 727 884 820">Arctic7 ~ Arctic9</td> <td data-bbox="884 727 1032 820">Fore peak, region 1 with longitudinal framing</td> <td data-bbox="1032 727 1207 820">Regions 1 and 2 (except fore peak), A3, A4, B3, B4</td> </tr> <tr> <td data-bbox="629 820 884 922">Arctic5, Arctic6</td> <td data-bbox="884 820 1032 922">Fore peak, region A1, B1, C1 with longitudinal framing</td> <td data-bbox="1032 820 1207 922">Regions 1 (except fore peak), 2, A3, B3</td> </tr> <tr> <td data-bbox="629 922 884 984">Arctic4</td> <td data-bbox="884 922 1032 984">—</td> <td data-bbox="1032 922 1207 984">Regions 1, A2, B2, A3, B3</td> </tr> </tbody> </table>	Ship class	Sketch of structure								Icebreaker5, Icebreaker6	Fore peak, after peak, region 1, 2 with longitudinal framing	Regions 2, A3, B3, D3, A4, B4	Other regions as per Table 3.9		Icebreaker3, Icebreaker4	Fore peak, after peak, region 1, 2 with longitudinal framing	Regions 1 and 2 (except fore peak and after peak) A3, B3, D3	Arctic7 ~ Arctic9	Fore peak, region 1 with longitudinal framing	Regions 1 and 2 (except fore peak), A3, A4, B3, B4	Arctic5, Arctic6	Fore peak, region A1, B1, C1 with longitudinal framing	Regions 1 (except fore peak), 2, A3, B3	Arctic4	—	Regions 1, A2, B2, A3, B3	<p data-bbox="1892 320 2078 435">- Typo : Table 3.14 => Table 3.15</p>
Ship class	Sketch of structure																											
																												
Icebreaker5, Icebreaker6	Fore peak, after peak, region 1, 2 with longitudinal framing	Regions 2, A3, B3, D3, A4, B4	Other regions as per Table 3.9																									
Icebreaker3, Icebreaker4	Fore peak, after peak, region 1, 2 with longitudinal framing	Regions 1 and 2 (except fore peak and after peak) A3, B3, D3																										
Arctic7 ~ Arctic9	Fore peak, region 1 with longitudinal framing	Regions 1 and 2 (except fore peak), A3, A4, B3, B4																										
Arctic5, Arctic6	Fore peak, region A1, B1, C1 with longitudinal framing	Regions 1 (except fore peak), 2, A3, B3																										
Arctic4	—	Regions 1, A2, B2, A3, B3																										

Present			Correction	Reason																
<p>Table 3.39 Location of ice damage</p> <table border="1"> <thead> <tr> <th>Item No.</th> <th>Arctic class</th> <th>Location of ice damage mentioned in 504. 1</th> </tr> </thead> <tbody> <tr> <td>1</td> <td>Arctic4 ~ Arctic9</td> <td rowspan="2">Anywhere in the ice damage area</td> </tr> <tr> <td>2</td> <td>Ice strengthened salvage ships with Arctic5 ~ Arctic9 class</td> </tr> <tr> <td>3</td> <td>Ice strengthened ships with Arctic5 and Arctic6 class not mentioned in item 2</td> <td>Between watertight bulkheads, platforms, decks and plating¹. With the hull length $L_f < 100m$ it is permitted not to comply with the requirements for damage trim and stability where engine room located aft is flooded in case of ice damage.</td> </tr> <tr> <td>4</td> <td>Ice strengthened ships with Arctic4 class not mentioned in item 2</td> <td>Between watertight bulkheads, platforms, decks and plating¹. With the hull length $L_f < 125m$ it is permitted not to comply with the requirements for damage trim and stability where engine room located aft is flooded in case of ice damage.</td> </tr> </tbody> </table> <p>Note ¹ : Where the distance between two consecutive watertight structures is less than the extent of damage, relative adjacent compartments shall be considered a single floodable compartment when checking damage stability.</p>					Item No.	Arctic class	Location of ice damage mentioned in 504. 1	1	Arctic4 ~ Arctic9	Anywhere in the ice damage area	2	Ice strengthened salvage ships with Arctic5 ~ Arctic9 class	3	Ice strengthened ships with Arctic5 and Arctic6 class not mentioned in item 2	Between watertight bulkheads, platforms, decks and plating ¹ . With the hull length $L_f < 100m$ it is permitted not to comply with the requirements for damage trim and stability where engine room located aft is flooded in case of ice damage.	4	Ice strengthened ships with Arctic4 class not mentioned in item 2	Between watertight bulkheads, platforms, decks and plating ¹ . With the hull length $L_f < 125m$ it is permitted not to comply with the requirements for damage trim and stability where engine room located aft is flooded in case of ice damage.		<p>-Typo :Table 3.39 => Table 3.48</p>
Item No.	Arctic class	Location of ice damage mentioned in 504. 1																		
1	Arctic4 ~ Arctic9	Anywhere in the ice damage area																		
2	Ice strengthened salvage ships with Arctic5 ~ Arctic9 class																			
3	Ice strengthened ships with Arctic5 and Arctic6 class not mentioned in item 2	Between watertight bulkheads, platforms, decks and plating ¹ . With the hull length $L_f < 100m$ it is permitted not to comply with the requirements for damage trim and stability where engine room located aft is flooded in case of ice damage.																		
4	Ice strengthened ships with Arctic4 class not mentioned in item 2	Between watertight bulkheads, platforms, decks and plating ¹ . With the hull length $L_f < 125m$ it is permitted not to comply with the requirements for damage trim and stability where engine room located aft is flooded in case of ice damage.																		

Present	Correction	Reason																	
	<p data-bbox="633 276 1057 304">Table 3.3948 Location of ice damage</p> <table border="1" data-bbox="633 325 1836 933"> <thead> <tr> <th data-bbox="633 325 712 411">Item No.</th> <th data-bbox="712 325 1122 411">Arctic class</th> <th data-bbox="1122 325 1836 411">Location of ice damage mentioned in 504. 1</th> </tr> </thead> <tbody> <tr> <td data-bbox="633 411 712 464">1</td> <td data-bbox="712 411 1122 464">Arctic4 ~ Arctic9</td> <td data-bbox="1122 411 1836 528" rowspan="2">Anywhere in the ice damage area</td> </tr> <tr> <td data-bbox="633 464 712 528">2</td> <td data-bbox="712 464 1122 528">Ice strengthened salvage ships with Arctic5 ~ Arctic9 class</td> </tr> <tr> <td data-bbox="633 528 712 683">3</td> <td data-bbox="712 528 1122 683">Ice strengthened ships with Arctic5 and Arctic6 class not mentioned in item 2</td> <td data-bbox="1122 528 1836 683">Between watertight bulkheads, platforms, decks and plating¹. With the hull length $L_f < 100m$ it is permitted not to comply with the requirements for damage trim and stability where engine room located aft is flooded in case of ice damage.</td> </tr> <tr> <td data-bbox="633 683 712 837">4</td> <td data-bbox="712 683 1122 837">Ice strengthened ships with Arctic4 class not mentioned in item 2</td> <td data-bbox="1122 683 1836 837">Between watertight bulkheads, platforms, decks and plating¹. With the hull length $L_f < 125m$ it is permitted not to comply with the requirements for damage trim and stability where engine room located aft is flooded in case of ice damage.</td> </tr> <tr> <td colspan="3" data-bbox="633 837 1836 933"> Note ¹ : Where the distance between two consecutive watertight structures is less than the extent of damage, relative adjacent compartments shall be considered a single floodable compartment when checking damage stability. </td> </tr> </tbody> </table>	Item No.	Arctic class	Location of ice damage mentioned in 504. 1	1	Arctic4 ~ Arctic9	Anywhere in the ice damage area	2	Ice strengthened salvage ships with Arctic5 ~ Arctic9 class	3	Ice strengthened ships with Arctic5 and Arctic6 class not mentioned in item 2	Between watertight bulkheads, platforms, decks and plating ¹ . With the hull length $L_f < 100m$ it is permitted not to comply with the requirements for damage trim and stability where engine room located aft is flooded in case of ice damage.	4	Ice strengthened ships with Arctic4 class not mentioned in item 2	Between watertight bulkheads, platforms, decks and plating ¹ . With the hull length $L_f < 125m$ it is permitted not to comply with the requirements for damage trim and stability where engine room located aft is flooded in case of ice damage.	Note ¹ : Where the distance between two consecutive watertight structures is less than the extent of damage, relative adjacent compartments shall be considered a single floodable compartment when checking damage stability.			<p data-bbox="1892 320 2078 435">- Typo :Table 3.39 => Table 3.48</p>
Item No.	Arctic class	Location of ice damage mentioned in 504. 1																	
1	Arctic4 ~ Arctic9	Anywhere in the ice damage area																	
2	Ice strengthened salvage ships with Arctic5 ~ Arctic9 class																		
3	Ice strengthened ships with Arctic5 and Arctic6 class not mentioned in item 2	Between watertight bulkheads, platforms, decks and plating ¹ . With the hull length $L_f < 100m$ it is permitted not to comply with the requirements for damage trim and stability where engine room located aft is flooded in case of ice damage.																	
4	Ice strengthened ships with Arctic4 class not mentioned in item 2	Between watertight bulkheads, platforms, decks and plating ¹ . With the hull length $L_f < 125m$ it is permitted not to comply with the requirements for damage trim and stability where engine room located aft is flooded in case of ice damage.																	
Note ¹ : Where the distance between two consecutive watertight structures is less than the extent of damage, relative adjacent compartments shall be considered a single floodable compartment when checking damage stability.																			

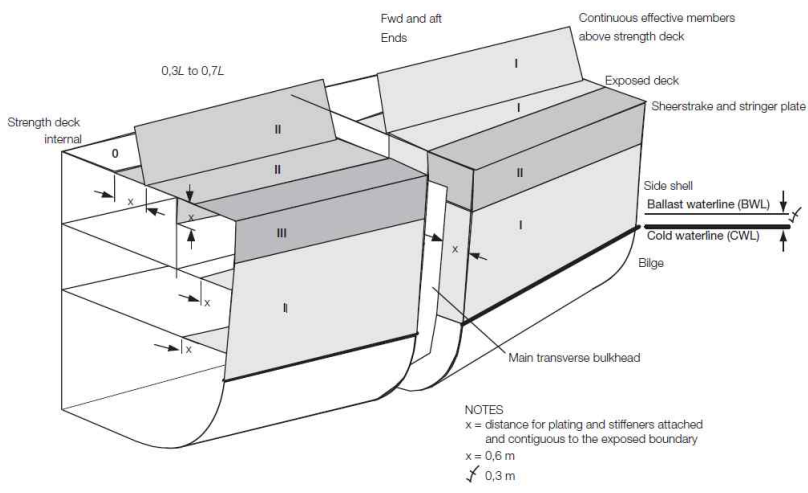
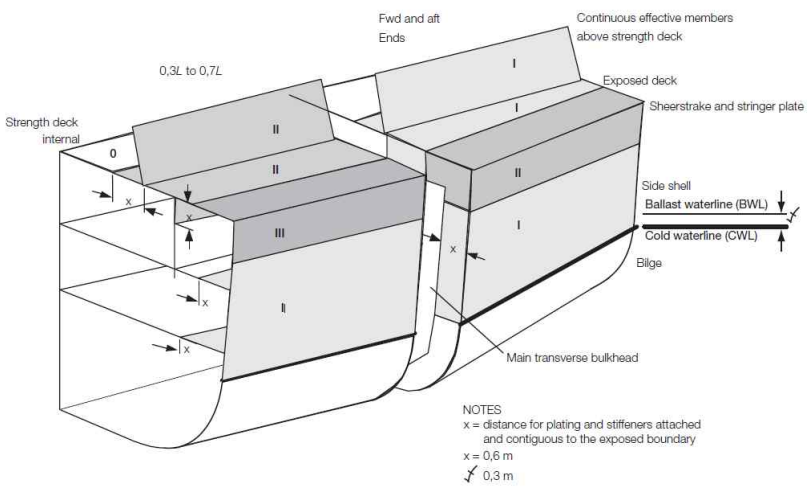
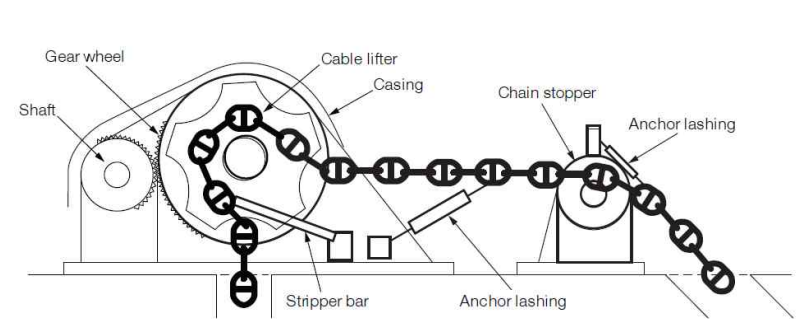
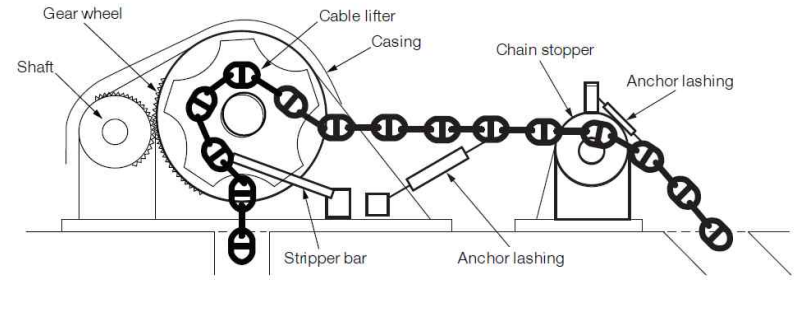
Present	Correction	Reason
 <p>Fig. 4.2 Distribution of material classes for cold weather</p>	 <p>Fig. 4.2 Distribution of material classes for cold weather</p>	<p>- Typo :delete “.” Fig. 4.2 =>Fig 4.2</p>
 <p>Fig. 4.3 Mooring and anchoring sub-components</p>	 <p>Fig. 4.3 Mooring and anchoring sub-components</p>	<p>- Typo :delete “.” Fig. 4.3 =>Fig 4.3</p>

Present	Correction	Reason
<p style="text-align: center;"> 〈Rules for the Classification of High Speed and Light Crafts〉 PART 1 CLASSIFICATION AND SURVEYS CHAPTER 1 CLASSIFICATION Section 1 General </p> <p>101. Application</p> <p>1. ~ 5. 〈omission〉</p> <p>6. Vehicle load method and securing device</p> <p>(1) ~ (3) 〈omission〉</p> <p>(4) Strength of securing device</p> <p>(A) The definitions of terms that are used to assess the strength of the securing devices are as follows.</p> <p>W = total weight of vehicle(load + vehicle weight) (ton)</p> <p>x, y, z = longitudinal, transverse and vertical distance from the center of rolling and pitching to the center of under consideration vehicle, respectively</p> <p>ϕ, ψ = rolling and pitching angle of ship as specified in Table 1 respectively (deg) (see Fig. 1)</p> <p>T_r, T_p = rolling and pitching cycle of ship as specified in Table 1 respectively (sec)</p> <p>V = vertical force to deck during rolling and pitching of ship (ton) (see Fig. 1)</p> <p>H_r = force acting to transverse direction which is parallel to deck during rolling of ship (ton) (see Fig. 1)</p> <p>H_p = force acting to longitudinal direction which is parallel to deck during pitching of ship (ton) (see Fig. 1)</p> <p>M_r = overturning moments during rolling of ship (ton-m) (see Fig. 2)</p> <p>SF_r, SF_p = forces acting on vehicle which is parallel to longitudinal and transverse deck respectively (ton)</p>	<p style="text-align: center;"> 〈Rules for the Classification of High Speed and Light Crafts〉 PART 1 CLASSIFICATION AND SURVEYS CHAPTER 1 CLASSIFICATION Section 1 General </p> <p>101. Application</p> <p>1. ~ 5. 〈same as present〉</p> <p>6. Vehicle load method and securing device</p> <p>(1) ~ (3) 〈same as present〉</p> <p>(4) Strength of securing device</p> <p>(A) The definitions of terms that are used to assess the strength of the securing devices are as follows.</p> <p>W = total weight of vehicle(load + vehicle weight) (ton)</p> <p>x, y, z = longitudinal, transverse and vertical distance from the center of rolling and pitching to the center of under consideration vehicle, respectively</p> <p>ϕ, ψ = rolling and pitching angle of ship as specified in Table 1.1.1 respectively (deg) (see Fig. 1.1.1)</p> <p>T_r, T_p = rolling and pitching cycle of ship as specified in Table 1.1.1 respectively (sec)</p> <p>V = vertical force to deck during rolling and pitching of ship (ton) (see Fig. 1.1.1)</p> <p>H_r = force acting to transverse direction which is parallel to deck during rolling of ship (ton) (see Fig. 1.1.1)</p> <p>H_p = force acting to longitudinal direction which is parallel to deck during pitching of ship (ton) (see Fig. 1.1.1)</p> <p>M_r = overturning moments during rolling of ship (ton-m) (see Fig. 1.1.2)</p> <p>SF_r, SF_p = forces acting on vehicle which is parallel to longitudinal and transverse deck respectively (ton)</p>	<p>-Typo</p> <p>:Table 1 =>Table 1.1.1</p> <p>Table 2 =>Table 1.1.2</p> <p>Fig. 1 => Fig 1.1.1</p> <p>Fig. 2 => Fig 1.1.2</p>

Present	Correction	Reason
<p> b_m = full width of vehicle (m) (see Fig. 2) b_i = spacing of wheels (m) (see Fig. 2) h_m = height from deck to the center of gravity of the vehicle (m) (see Fig. 2) L_r, L_p = sum of the transverse and longitudinal horizontal component which movable securing devices can withstand (ton) M_l = sum of the force to resist for vehicle overturning moment by movable securing devices (ton) n = number of movable securing devices used for one vehicle α, β = transverse and longitudinal angle between movable securing devices and deck respectively (deg) (see Fig. 2) h = height from deck to the point of vehicle securing (m) (see Fig. 2) T = safety working load of movable securing devices which is divided breaking load with safety factor of Table 1 (ton) μ = friction coefficients between vehicle and deck, as shown below tire(rubber) / non-slipped paint: 0.7 tire(rubber) / steel deck: 0.3 steel / steel deck: 0.1(when dry) steel / steel deck: 0.0(when wet) timber / steel deck: 0.3 (B) The loads acting on the securing device is to be determined in consideration of the movements of ship which is described in the Table 1. </p>	<p> b_m = full width of vehicle (m) (see Fig: 1.1.2) b_i = spacing of wheels (m) (see Fig: 1.1.2) h_m = height from deck to the center of gravity of the vehicle (m) (see Fig: 1.1.2) L_r, L_p = sum of the transverse and longitudinal horizontal component which movable securing devices can withstand (ton) M_l = sum of the force to resist for vehicle overturning moment by movable securing devices (ton) n = number of movable securing devices used for one vehicle α, β = transverse and longitudinal angle between movable securing devices and deck respectively (deg) (see Fig: 1.1.2) h = height from deck to the point of vehicle securing (m) (see Fig: 1.1.2) T = safety working load of movable securing devices which is divided breaking load with safety factor of Table 1.1.1 (ton) μ = friction coefficients between vehicle and deck, as shown below tire(rubber) / non-slipped paint: 0.7 tire(rubber) / steel deck: 0.3 steel / steel deck: 0.1(when dry) steel / steel deck: 0.0(when wet) timber / steel deck: 0.3 (B) The loads acting on the securing device is to be determined in consideration of the movements of ship which is described in the Table 1.1.1. </p>	

Present

Table 1 Ship motion

Rolling		Pitching		Safety factor
degree	cycle 3)	degree	cycle	
10°	cycle of ship	5°	5 sec	4 over

(Note)

1. KG' is the value obtained from the following formula.

$$KG' = 0.5(KG + KB)$$

KG = the vertical position of the centric of the ship

KB = the vertical position of the buoyancy centric of the ship

2. The centric of pitching is to be longitudinal position of the centric of the ship.
3. The rolling cycle of the ship may be taken from T_R of **Pt 3, Ch 2, 203. 2.** of the Rule.

(C) Each component of the loads caused by motions of the ship is shown in **Fig. 1** and **Table 2**.

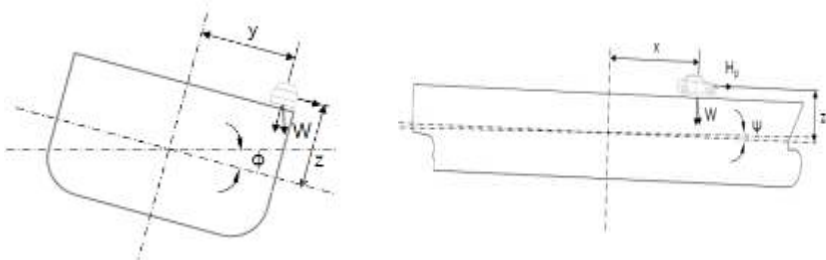

Fig. 1 Motions of the ship

Correction

Table 1.1.1 Ship motion

Rolling		Pitching		Safety factor
degree	cycle 3)	degree	cycle	
10°	cycle of ship	5°	5 sec	4 over

(Note)

1. KG' is the value obtained from the following formula.

$$KG' = 0.5(KG + KB)$$

KG = the vertical position of the centric of the ship

KB = the vertical position of the buoyancy centric of the ship

2. The centric of pitching is to be longitudinal position of the centric of the ship.
3. The rolling cycle of the ship may be taken from T_R of **Pt 3, Ch 2, 203. 2.** of the Rule.

(C) Each component of the loads caused by motions of the ship is shown in **Fig: 1.1.1** and **Table 1.1.2**.

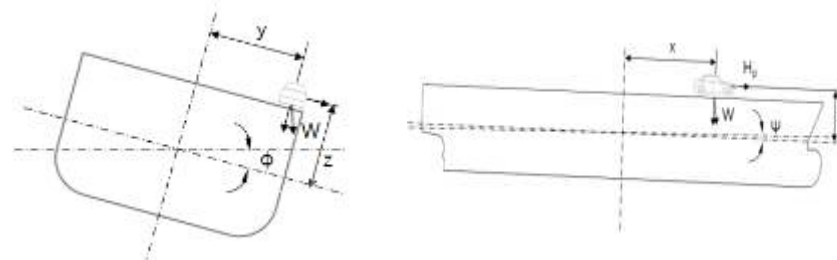

Fig: 1.1.1 Motions of the ship

Present

Table 2 Load components

Type		Load components (ton)		
		Vertical force	Horizontal force	
			transverse	longitudinal
Static load	Rolling	$W \cos \phi$	$W \sin \phi$	—
	Pitching	$W \cos \psi$	—	$W \sin \psi$
	Combination	$W \cos (0.71 \phi) \cos (0.71 \psi)$	$W \sin (0.71 \phi)$	$W \sin (0.71 \psi)$
Dynamic load	Rolling	$0.07024 W \frac{\phi}{T_r^2} y$	$0.070247 W \frac{\phi}{T_r^2}$	—
	Pitching	$0.07024 W \frac{\psi}{T_p^2} x$	—	$0.07024 W \frac{\psi}{T_p^2} z$

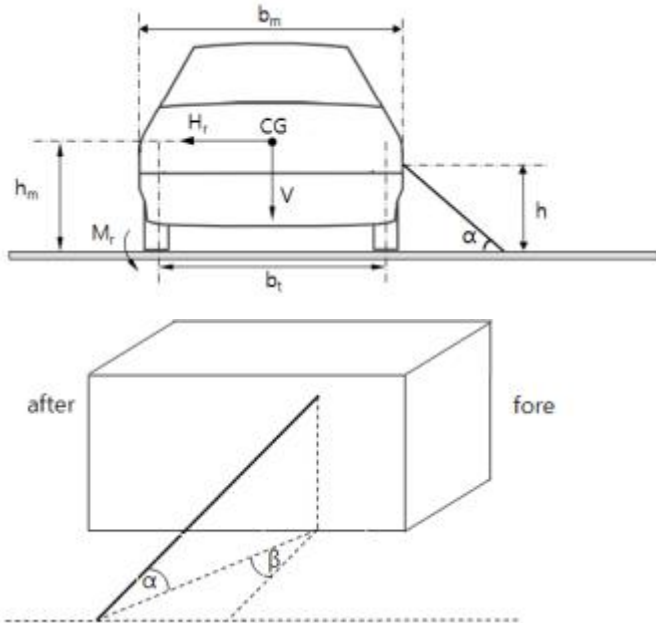

Fig. 2 Various dimensions during vehicle securing

Correction

Table 1.1.2 Load components

Type		Load components (ton)		
		Vertical force	Horizontal force	
			transverse	longitudinal
Static load	Rolling	$W \cos \phi$	$W \sin \phi$	—
	Pitching	$W \cos \psi$	—	$W \sin \psi$
	Combination	$W \cos (0.71 \phi) \cos (0.71 \psi)$	$W \sin (0.71 \phi)$	$W \sin (0.71 \psi)$
Dynamic load	Rolling	$0.07024 W \frac{\phi}{T_r^2} y$	$0.070247 W \frac{\phi}{T_r^2}$	—
	Pitching	$0.07024 W \frac{\psi}{T_p^2} x$	—	$0.07024 W \frac{\psi}{T_p^2} z$

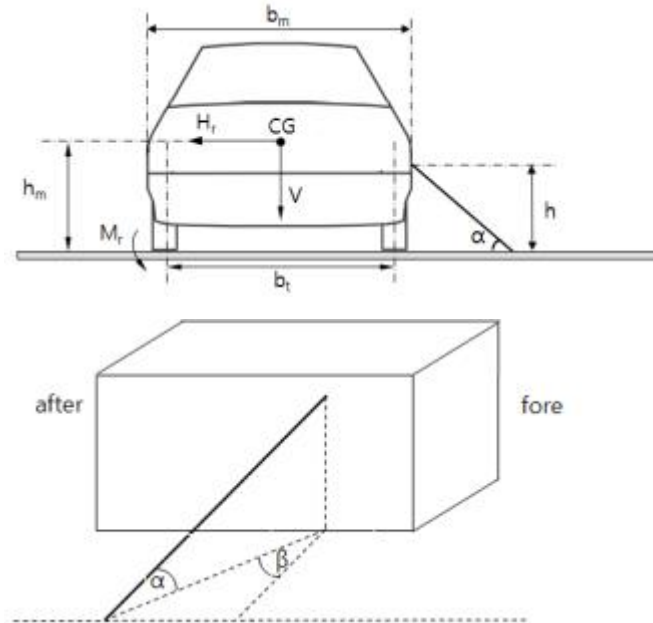

Fig. 1.1.2 Various dimensions during vehicle securing

Reason

Present	Correction	Reason																																
<p align="center">Annex 3-1 Guidance for the Direct Strength Assessment</p> <p>1. Direct strength calculation of steel ships</p> <p><omit></p> <p>(D) Allowable stresses</p> <p>(a) Allowable stress level for stiffeners is given in Table 3.1.</p> <p>(b) Stiffeners are in no case to have web and flange thickness less than given in Pt 3, Ch 3, 601.</p> <p>Table 3.1 Allowable Stresses for Stiffeners</p> <table border="1" data-bbox="107 654 967 1161"> <tr> <td rowspan="2">Nominal local bending stress</td> <td>General</td> <td>$\sigma = 180/K$ (N/mm²)</td> </tr> <tr> <td>Watertight bulkheads except collision bulkhead</td> <td>$\sigma = 245/K$ (N/mm²)</td> </tr> <tr> <td colspan="2">Combined local bending stress/girder stress / extreme longitudinal stress</td> <td>$\sigma = 230 \sim 265/K^{(*)}$ (N/m</td> </tr> <tr> <td rowspan="2">Nominal shear stress</td> <td>General</td> <td>$\tau = 90/K$ (N/mm²)</td> </tr> <tr> <td>Watertight bulkheads except collision bulkhead</td> <td>$\tau = 120/K$ (N/mm²)</td> </tr> <tr> <td colspan="3">(*) : In case of girder stress, longitudinal stress is as specified in Pt 3, Ch 3, 403.</td> </tr> </table>	Nominal local bending stress	General	$\sigma = 180/K$ (N/mm ²)	Watertight bulkheads except collision bulkhead	$\sigma = 245/K$ (N/mm ²)	Combined local bending stress/girder stress / extreme longitudinal stress		$\sigma = 230 \sim 265/K^{(*)}$ (N/m	Nominal shear stress	General	$\tau = 90/K$ (N/mm ²)	Watertight bulkheads except collision bulkhead	$\tau = 120/K$ (N/mm ²)	(*) : In case of girder stress, longitudinal stress is as specified in Pt 3, Ch 3, 403 .			<p align="center">Annex 3-1 Guidance for the Direct Strength Assessment</p> <p>1. Direct strength calculation of steel ships</p> <p><omit></p> <p>(D) Allowable stresses</p> <p>(a) Allowable stress level for stiffeners is given in Table 3.1.</p> <p>(b) Stiffeners are in no case to have web and flange thickness less than given in Pt 3, Ch 3, 601.</p> <p>Table 3.1 Allowable Stresses for Stiffeners</p> <table border="1" data-bbox="999 654 1859 1161"> <tr> <td rowspan="2">Nominal local bending stress</td> <td>General</td> <td>$\sigma = 180/K$ (N/mm²)</td> </tr> <tr> <td>Watertight bulkheads except collision bulkhead</td> <td>$\sigma = 245/K$ (N/mm²)</td> </tr> <tr> <td colspan="2">Combined local bending stress/girder stress / extreme longitudinal stress</td> <td>$\sigma = 230 \sim 265/K^{(*)}$ (N/m</td> </tr> <tr> <td rowspan="2">Nominal shear stress</td> <td>General</td> <td>$\tau = 90/K$ (N/mm²)</td> </tr> <tr> <td>Watertight bulkheads except collision bulkhead</td> <td>$\tau = 120/K$ (N/mm²)</td> </tr> <tr> <td colspan="3">(*) : In case of girder stress, longitudinal stress is as specified in Pt 3, Ch 3, 403.</td> </tr> </table>	Nominal local bending stress	General	$\sigma = 180/K$ (N/mm ²)	Watertight bulkheads except collision bulkhead	$\sigma = 245/K$ (N/mm ²)	Combined local bending stress/girder stress / extreme longitudinal stress		$\sigma = 230 \sim 265/K^{(*)}$ (N/m	Nominal shear stress	General	$\tau = 90/K$ (N/mm ²)	Watertight bulkheads except collision bulkhead	$\tau = 120/K$ (N/mm ²)	(*) : In case of girder stress, longitudinal stress is as specified in Pt 3, Ch 3, 403 .			<p>-Typo :Table 3.1 =>Table 1</p>
Nominal local bending stress		General	$\sigma = 180/K$ (N/mm ²)																															
	Watertight bulkheads except collision bulkhead	$\sigma = 245/K$ (N/mm ²)																																
Combined local bending stress/girder stress / extreme longitudinal stress		$\sigma = 230 \sim 265/K^{(*)}$ (N/m																																
Nominal shear stress	General	$\tau = 90/K$ (N/mm ²)																																
	Watertight bulkheads except collision bulkhead	$\tau = 120/K$ (N/mm ²)																																
(*) : In case of girder stress, longitudinal stress is as specified in Pt 3, Ch 3, 403 .																																		
Nominal local bending stress	General	$\sigma = 180/K$ (N/mm ²)																																
	Watertight bulkheads except collision bulkhead	$\sigma = 245/K$ (N/mm ²)																																
Combined local bending stress/girder stress / extreme longitudinal stress		$\sigma = 230 \sim 265/K^{(*)}$ (N/m																																
Nominal shear stress	General	$\tau = 90/K$ (N/mm ²)																																
	Watertight bulkheads except collision bulkhead	$\tau = 120/K$ (N/mm ²)																																
(*) : In case of girder stress, longitudinal stress is as specified in Pt 3, Ch 3, 403 .																																		

Present	Correction	Reason
<p>⟨omit⟩</p> <p>(D) Allowable stresses (a) The equivalent stress is defined as:</p> $\sigma_e = \sqrt{\sigma_x^2 + \sigma_y^2 - \sigma_x \sigma_y + 3\tau^2}$ <p>σ_x : normal stress in x-direction σ_y : normal stress in y-direction τ : Shear stress in the xy-plane</p> <p>(b) For girders in general, the following stresses given in Table 3.2 are normally acceptable.</p>	<p>⟨omit⟩</p> <p>(D) Allowable stresses (a) The equivalent stress is defined as:</p> $\sigma_e = \sqrt{\sigma_x^2 + \sigma_y^2 - \sigma_x \sigma_y + 3\tau^2}$ <p>σ_x : normal stress in x-direction σ_y : normal stress in y-direction τ : Shear stress in the xy-plane</p> <p>(b) For girders in general, the following stresses given in Table-3:2 are normally acceptable.</p>	<p>-Typo :Table 3.2 => Table 2</p>

Present				Correction				Reason																																						
Table 3.2 Allowable Stresses for Girders <table border="1"> <thead> <tr> <th></th> <th>Girders in general</th> <th>For girders on watertight bulkheads except for the collision bulkhead</th> <th>For transverse structures and partial longitudinal structures supporting deck-houses, containers etc. in the rolling and pitching conditions</th> </tr> </thead> <tbody> <tr> <td>Normal stresses (σ)</td> <td>160 /K (N/mm²)</td> <td>220 /K (N/mm²)</td> <td>210/K (N/mm²)</td> </tr> <tr> <td rowspan="2">Mean shear stresses (τ)</td> <td>90 /K (N/mm²) with one plate flange</td> <td>120 /K (N/mm²) with one plate flange</td> <td>115/K (N/mm²) with one plate flange</td> </tr> <tr> <td>100 /K (N/mm²) with two plate flanges</td> <td>130 /K (N/mm²) with two plate flanges</td> <td>125/K (N/mm²) with two plate flanges</td> </tr> <tr> <td>Equivalent stresses (σ_e)</td> <td>180 /K (N/mm²)</td> <td>240 /K (N/mm²)</td> <td>230/K (N/mm²)</td> </tr> </tbody> </table>					Girders in general	For girders on watertight bulkheads except for the collision bulkhead	For transverse structures and partial longitudinal structures supporting deck-houses, containers etc. in the rolling and pitching conditions	Normal stresses (σ)	160 /K (N/mm ²)	220 /K (N/mm ²)	210/K (N/mm ²)	Mean shear stresses (τ)	90 /K (N/mm ²) with one plate flange	120 /K (N/mm ²) with one plate flange	115/K (N/mm ²) with one plate flange	100 /K (N/mm ²) with two plate flanges	130 /K (N/mm ²) with two plate flanges	125/K (N/mm ²) with two plate flanges	Equivalent stresses (σ_e)	180 /K (N/mm ²)	240 /K (N/mm ²)	230/K (N/mm ²)	Table 3:2 Allowable Stresses for Girders <table border="1"> <thead> <tr> <th></th> <th>Girders in general</th> <th>For girders on watertight bulkheads except for the collision bulkhead</th> <th>For transverse structures and partial longitudinal structures supporting deck-houses, containers etc. in the rolling and pitching conditions</th> </tr> </thead> <tbody> <tr> <td>Normal stresses (σ)</td> <td>160 /K (N/mm²)</td> <td>220 /K (N/mm²)</td> <td>210/K (N/mm²)</td> </tr> <tr> <td rowspan="2">Mean shear stresses (τ)</td> <td>90 /K (N/mm²) with one plate flange</td> <td>120 /K (N/mm²) with one plate flange</td> <td>115/K (N/mm²) with one plate flange</td> </tr> <tr> <td>100 /K (N/mm²) with two plate flanges</td> <td>130 /K (N/mm²) with two plate flanges</td> <td>125/K (N/mm²) with two plate flanges</td> </tr> <tr> <td>Equivalent stresses (σ_e)</td> <td>180 /K (N/mm²)</td> <td>240 /K (N/mm²)</td> <td>230/K (N/mm²)</td> </tr> </tbody> </table>					Girders in general	For girders on watertight bulkheads except for the collision bulkhead	For transverse structures and partial longitudinal structures supporting deck-houses, containers etc. in the rolling and pitching conditions	Normal stresses (σ)	160 /K (N/mm ²)	220 /K (N/mm ²)	210/K (N/mm ²)	Mean shear stresses (τ)	90 /K (N/mm ²) with one plate flange	120 /K (N/mm ²) with one plate flange	115/K (N/mm ²) with one plate flange	100 /K (N/mm ²) with two plate flanges	130 /K (N/mm ²) with two plate flanges	125/K (N/mm ²) with two plate flanges	Equivalent stresses (σ_e)	180 /K (N/mm ²)	240 /K (N/mm ²)	230/K (N/mm ²)	- Typo :Table 3.2 => Table 2
	Girders in general	For girders on watertight bulkheads except for the collision bulkhead	For transverse structures and partial longitudinal structures supporting deck-houses, containers etc. in the rolling and pitching conditions																																											
Normal stresses (σ)	160 /K (N/mm ²)	220 /K (N/mm ²)	210/K (N/mm ²)																																											
Mean shear stresses (τ)	90 /K (N/mm ²) with one plate flange	120 /K (N/mm ²) with one plate flange	115/K (N/mm ²) with one plate flange																																											
	100 /K (N/mm ²) with two plate flanges	130 /K (N/mm ²) with two plate flanges	125/K (N/mm ²) with two plate flanges																																											
Equivalent stresses (σ_e)	180 /K (N/mm ²)	240 /K (N/mm ²)	230/K (N/mm ²)																																											
	Girders in general	For girders on watertight bulkheads except for the collision bulkhead	For transverse structures and partial longitudinal structures supporting deck-houses, containers etc. in the rolling and pitching conditions																																											
Normal stresses (σ)	160 /K (N/mm ²)	220 /K (N/mm ²)	210/K (N/mm ²)																																											
Mean shear stresses (τ)	90 /K (N/mm ²) with one plate flange	120 /K (N/mm ²) with one plate flange	115/K (N/mm ²) with one plate flange																																											
	100 /K (N/mm ²) with two plate flanges	130 /K (N/mm ²) with two plate flanges	125/K (N/mm ²) with two plate flanges																																											
Equivalent stresses (σ_e)	180 /K (N/mm ²)	240 /K (N/mm ²)	230/K (N/mm ²)																																											

Present	Correction	Reason																								
<p data-bbox="188 252 264 280">〈omit〉</p> <p data-bbox="203 296 920 357">(D) Allowable stresses Allowable stress level for stiffeners is given in Table 3.3.</p> <p data-bbox="107 395 591 424">Table 3.3 Allowable Stresses for Stiffeners</p> <table border="1" data-bbox="107 443 967 625"> <tr> <td data-bbox="107 443 654 497">Nominal local bending stress</td> <td data-bbox="654 443 967 497">$\sigma = 160 / K(\text{N/mm}^2)$</td> </tr> <tr> <td data-bbox="107 497 654 574">Combined local bending stress or girder stress or longitudinal stress</td> <td data-bbox="654 497 967 574">$\sigma = 220 / K(\text{N/mm}^2)$</td> </tr> <tr> <td data-bbox="107 574 654 625">Nominal shear stress</td> <td data-bbox="654 574 967 625">$\tau = 90 / K(\text{N/mm}^2)$</td> </tr> </table> <p data-bbox="165 708 241 737">〈omit〉</p> <p data-bbox="248 753 965 813">(c) For girders in general, the following stresses given in Table 3.4 are normally acceptable.</p> <p data-bbox="107 852 568 880">Table 3.4 Allowable Stresses for Girders</p> <table border="1" data-bbox="107 900 967 1114"> <tr> <td data-bbox="107 900 344 954">Normal stress(σ)</td> <td data-bbox="344 900 967 954">$160 / K (\text{N/mm}^2)$</td> </tr> <tr> <td data-bbox="107 954 344 1031">Mean shear stress(τ)</td> <td data-bbox="344 954 967 1031">$90 / K (\text{N/mm}^2)$ with one plate flange $100 / K (\text{N/mm}^2)$ with two plate flanges</td> </tr> <tr> <td data-bbox="107 1031 344 1114">Equivalent stress(σ_e)</td> <td data-bbox="344 1031 967 1114">$180 / K (\text{N/mm}^2)$</td> </tr> </table>	Nominal local bending stress	$\sigma = 160 / K(\text{N/mm}^2)$	Combined local bending stress or girder stress or longitudinal stress	$\sigma = 220 / K(\text{N/mm}^2)$	Nominal shear stress	$\tau = 90 / K(\text{N/mm}^2)$	Normal stress(σ)	$160 / K (\text{N/mm}^2)$	Mean shear stress(τ)	$90 / K (\text{N/mm}^2)$ with one plate flange $100 / K (\text{N/mm}^2)$ with two plate flanges	Equivalent stress(σ_e)	$180 / K (\text{N/mm}^2)$	<p data-bbox="1043 252 1120 280">〈omit〉</p> <p data-bbox="1093 296 1809 357">(D) Allowable stresses Allowable stress level for stiffeners is given in Table 3.3.</p> <p data-bbox="999 395 1482 424">Table 3.3 Allowable Stresses for Stiffeners</p> <table border="1" data-bbox="999 443 1859 625"> <tr> <td data-bbox="999 443 1545 497">Nominal local bending stress</td> <td data-bbox="1545 443 1859 497">$\sigma = 160 / K(\text{N/mm}^2)$</td> </tr> <tr> <td data-bbox="999 497 1545 574">Combined local bending stress or girder stress or longitudinal stress</td> <td data-bbox="1545 497 1859 574">$\sigma = 220 / K(\text{N/mm}^2)$</td> </tr> <tr> <td data-bbox="999 574 1545 625">Nominal shear stress</td> <td data-bbox="1545 574 1859 625">$\tau = 90 / K(\text{N/mm}^2)$</td> </tr> </table> <p data-bbox="1057 708 1133 737">〈omit〉</p> <p data-bbox="1140 753 1856 813">(c) For girders in general, the following stresses given in Table 3.4 are normally acceptable.</p> <p data-bbox="999 852 1460 880">Table 3.4 Allowable Stresses for Girders</p> <table border="1" data-bbox="999 900 1859 1114"> <tr> <td data-bbox="999 900 1236 954">Normal stress(σ)</td> <td data-bbox="1236 900 1859 954">$160 / K (\text{N/mm}^2)$</td> </tr> <tr> <td data-bbox="999 954 1236 1031">Mean shear stress(τ)</td> <td data-bbox="1236 954 1859 1031">$90 / K (\text{N/mm}^2)$ with one plate flange $100 / K (\text{N/mm}^2)$ with two plate flanges</td> </tr> <tr> <td data-bbox="999 1031 1236 1114">Equivalent stress(σ_e)</td> <td data-bbox="1236 1031 1859 1114">$180 / K (\text{N/mm}^2)$</td> </tr> </table>	Nominal local bending stress	$\sigma = 160 / K(\text{N/mm}^2)$	Combined local bending stress or girder stress or longitudinal stress	$\sigma = 220 / K(\text{N/mm}^2)$	Nominal shear stress	$\tau = 90 / K(\text{N/mm}^2)$	Normal stress(σ)	$160 / K (\text{N/mm}^2)$	Mean shear stress(τ)	$90 / K (\text{N/mm}^2)$ with one plate flange $100 / K (\text{N/mm}^2)$ with two plate flanges	Equivalent stress(σ_e)	$180 / K (\text{N/mm}^2)$	<p data-bbox="1895 245 2038 357">-Typo :Table 3.3 => Table 3</p> <p data-bbox="1895 759 2038 871">-Typo :Table 3.4 => Table 4</p>
Nominal local bending stress	$\sigma = 160 / K(\text{N/mm}^2)$																									
Combined local bending stress or girder stress or longitudinal stress	$\sigma = 220 / K(\text{N/mm}^2)$																									
Nominal shear stress	$\tau = 90 / K(\text{N/mm}^2)$																									
Normal stress(σ)	$160 / K (\text{N/mm}^2)$																									
Mean shear stress(τ)	$90 / K (\text{N/mm}^2)$ with one plate flange $100 / K (\text{N/mm}^2)$ with two plate flanges																									
Equivalent stress(σ_e)	$180 / K (\text{N/mm}^2)$																									
Nominal local bending stress	$\sigma = 160 / K(\text{N/mm}^2)$																									
Combined local bending stress or girder stress or longitudinal stress	$\sigma = 220 / K(\text{N/mm}^2)$																									
Nominal shear stress	$\tau = 90 / K(\text{N/mm}^2)$																									
Normal stress(σ)	$160 / K (\text{N/mm}^2)$																									
Mean shear stress(τ)	$90 / K (\text{N/mm}^2)$ with one plate flange $100 / K (\text{N/mm}^2)$ with two plate flanges																									
Equivalent stress(σ_e)	$180 / K (\text{N/mm}^2)$																									

Present	Correction	Reason
<p>3. Direct strength calculation of FRP ships</p> <p>(1) General</p> <p>(A) Direct calculation using the full stiffness and strength properties of the laminates in all directions will be accepted based on the criteria given below.</p> <p>(a) Laminates are dimensioned in accordance with the Tsai-Wu composite strength criterion.</p> <p>(b) The failure strength ratio, R, for a ply in the Tsai-Wu failure criterion is expressed as:</p> $(F_{ij} \sigma_i \sigma_j) R^2 + (F_i \sigma_i) R - 1 = 0, \quad i, j = 1, 2, 3, 4, 5, 6$ <p>Where $R \leq 1$ indicates ply failure.</p> <p>The terms in the failure criterion are defined in the notes in Table 3.5</p> <p>(c) All relevant load combinations for the laminate panel are to be considered.</p> <p>(2) Allowable stress and deflections</p> <p>(A) For direct calculations in accordance with (1) (A) (b), the failure strength ratio, R, is not to be less than the values given in Table 3.5. Core shear stresses in sandwich panels shall be in accordance with Pt 3, Ch 5, Sec 5. Panel deflections shall not be greater than specified in Pt 3, Ch 5, Sec. 5 and Sec 6.</p>	<p>3. Direct strength calculation of FRP ships</p> <p>(1) General</p> <p>(A) Direct calculation using the full stiffness and strength properties of the laminates in all directions will be accepted based on the criteria given below.</p> <p>(a) Laminates are dimensioned in accordance with the Tsai-Wu composite strength criterion.</p> <p>(b) The failure strength ratio, R, for a ply in the Tsai-Wu failure criterion is expressed as:</p> $(F_{ij} \sigma_i \sigma_j) R^2 + (F_i \sigma_i) R - 1 = 0, \quad i, j = 1, 2, 3, 4, 5, 6$ <p>Where $R \leq 1$ indicates ply failure.</p> <p>The terms in the failure criterion are defined in the notes in Table 3.5</p> <p>(c) All relevant load combinations for the laminate panel are to be considered.</p> <p>(2) Allowable stress and deflections</p> <p>(A) For direct calculations in accordance with (1) (A) (b), the failure strength ratio, R, is not to be less than the values given in Table 3.5. Core shear stresses in sandwich panels shall be in accordance with Pt 3, Ch 5, Sec 5. Panel deflections shall not be greater than specified in Pt 3, Ch 5, Sec. 5 and Sec 6.</p>	<p>-Typo :Table 3.5 =>Table 5</p>

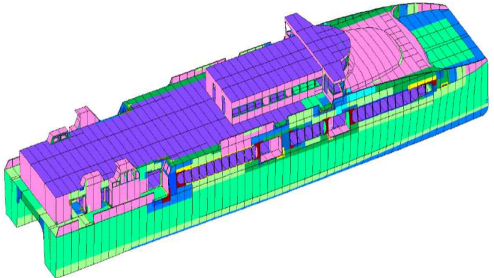
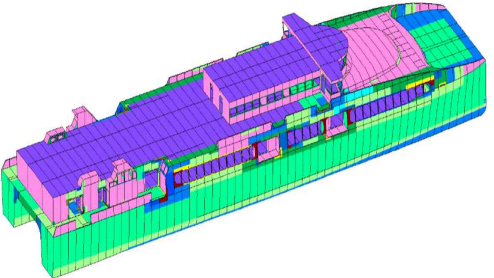
Present	Correction	Reason
<p>(2) Direct strength calculation of full ship structure</p> <p>(A) Structural modeling</p> <p>(a) The direct strength calculation is to be applied for the hull structure that contributes to the hull girder strength.</p> <p>(b) In case of modeling with plate or shell element, in principle, the finite element division is divided into two or more elements between adjacent web frames in the longitudinal direction and by the spacing of longitudinals in the width direction. An example of the full ship structure model is shown in Figure 3.1.1.</p> <p>(c) In case aluminum extruded members are used as structural members, the orthotropic elements or composed model with plate and stiffener elements should be used for the members.</p>  <p>Figure 3.1.1 An example of the full ship structural model</p>	<p>(2) Direct strength calculation of full ship structure</p> <p>(A) Structural modeling</p> <p>(a) The direct strength calculation is to be applied for the hull structure that contributes to the hull girder strength.</p> <p>(b) In case of modeling with plate or shell element, in principle, the finite element division is divided into two or more elements between adjacent web frames in the longitudinal direction and by the spacing of longitudinals in the width direction. An example of the full ship structure model is shown in Figure 3-1.1.</p> <p>(c) In case aluminum extruded members are used as structural members, the orthotropic elements or composed model with plate and stiffener elements should be used for the members.</p>  <p>Figure 3-1.1 An example of the full ship structural model</p>	<p>-Typo :Fig 3.1.1 =>Fig 1</p>

Present	Correction	Reason
<p>(C) Load conditions</p> <p>(a) Full ship analysis is to be performed for the load cases derived from ship motion analysis acceptable to the Society. If the hull girder loads in Pt 3, Ch 2, Sec 4 of the Rules is applied instead of the loads from ship motion analysis, the strength evaluation can be performed for the load cases shown in Table 3-6.</p> <p>(b) In accordance with Pt 3, Ch 2, Sec 3 304. ~ 307. of the Rules, the hull weight, cargo/passenger load and sea water pressure are to be applied in the structural model in advance applying the hull girder load.</p> <p>(c) For vertical bending moment, the larger moment is to be used compared with the bending moment (M_B) due to impact load in Pt 3, Ch 2, Sec 4, 401. 2 of the Rules and the hogging/sagging moment (M_{hog}, M_{sag}) in 401. 4. In order to apply the vertical bending moment defined in the above regulation to the full ship model, the weight and buoyancy can be distributed in way of longitudinal direction of the hull as shown in the example in Figure 3.1.2. In the case of weight, the distributed loads can be applied to the deck by frame spacing, and in the case of buoyancy, the concentrated loads can be applied to the keel position by frame spacing as shown in Figure 3.1.3.</p> <p>(d) For the transverse bending moment (M_S), the horizontal split force (F_y) of Pt 3, Ch 2, Sec 4, 402. 2. (2) of the Rules can be applied as shown in Figure 3.1.4.</p> <p>(e) The longitudinal/transverse torsional moment of Pt 3, Ch 2, Sec 4 402. 3 and 4 of the Rules can be applied to the bulkhead deck or keel by using pitch connecting force(F_p) as shown in Figure 3.1.5. This force is as follows.</p>	<p>(C) Load conditions</p> <p>(a) Full ship analysis is to be performed for the load cases derived from ship motion analysis acceptable to the Society. If the hull girder loads in Pt 3, Ch 2, Sec 4 of the Rules is applied instead of the loads from ship motion analysis, the strength evaluation can be performed for the load cases shown in Table 3-6.</p> <p>(b) In accordance with Pt 3, Ch 2, Sec 3 304. ~ 307. of the Rules, the hull weight, cargo/passenger load and sea water pressure are to be applied in the structural model in advance applying the hull girder load.</p> <p>(c) For vertical bending moment, the larger moment is to be used compared with the bending moment (M_B) due to impact load in Pt 3, Ch 2, Sec 4, 401. 2 of the Rules and the hogging/sagging moment (M_{hog}, M_{sag}) in 401. 4. In order to apply the vertical bending moment defined in the above regulation to the full ship model, the weight and buoyancy can be distributed in way of longitudinal direction of the hull as shown in the example in Figure 3-1.2. In the case of weight, the distributed loads can be applied to the deck by frame spacing, and in the case of buoyancy, the concentrated loads can be applied to the keel position by frame spacing as shown in Figure 3-1.3.</p> <p>(d) For the transverse bending moment (M_S), the horizontal split force (F_y) of Pt 3, Ch 2, Sec 4, 402. 2. (2) of the Rules can be applied as shown in Figure 3-1.4.</p> <p>(e) The longitudinal/transverse torsional moment of Pt 3, Ch 2, Sec 4 402. 3 and 4 of the Rules can be applied to the bulkhead deck or keel by using pitch connecting force(F_p) as shown in Figure 3-1.5. This force is as follows.</p>	<p>-Typo :Fig 3.1.2 =>Fig 2 Fig 3.1.3 =>Fig 3 Fig 3.1.4 =>Fig 4 Fig 3.1.5 =>Fig 5</p> <p>Table 3-6 => Table 6</p>

Present

Table 3-6 Load cases for longitudinal strength evaluation of catamaran

No	Load cases		Pt 3, Ch 2 of the Rules
1	Vertical bending moment (Hogging)	Max(Mhog , MB)	401.2.(2), 401.4.(2)
2	Vertical bending moment (Sagging)	Max(Msag , MB)	401.2.(3), 401.4.(2)
3	Transverse bending moment	MS	402.2.(2)
4	Longitudinal/transverse torsional moment	MP + MT	402.3 및 402.4
5	Load combination 1	0.8 Max(Msag , MB) + 0.6(MP + MT)	
6	Load combination 2	0.6 Max(Msag , MB) + 0.8(MP + MT)	
7	Load combination 3	0.7Ms + (MP + MT)	
8	Load combination 4	Ms + 0.7(MP + Mt)	

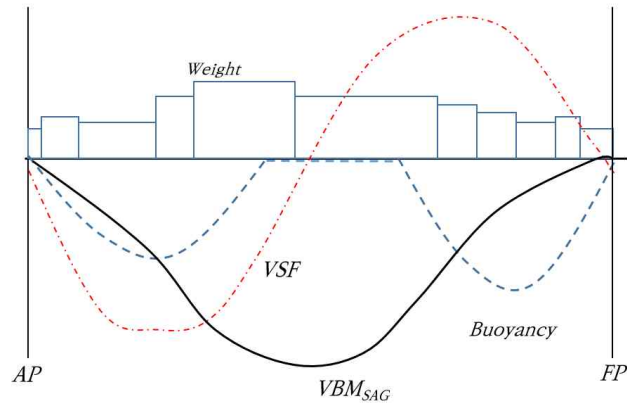

Figure 3.1.2 An example of weight, buoyancy, shear force and bending moment diagram (refer to Figure 3.2.11 of the Rules)

Correction

Table 3-6 Load cases for longitudinal strength evaluation of catamaran

No	Load cases		Pt 3, Ch 2 of the Rules
1	Vertical bending moment (Hogging)	Max(Mhog , MB)	401.2.(2), 401.4.(2)
2	Vertical bending moment (Sagging)	Max(Msag , MB)	401.2.(3), 401.4.(2)
3	Transverse bending moment	MS	402.2.(2)
4	Longitudinal/transverse torsional moment	MP + MT	402.3 및 402.4
5	Load combination 1	0.8 Max(Msag , MB) + 0.6(MP + MT)	
6	Load combination 2	0.6 Max(Msag , MB) + 0.8(MP + MT)	
7	Load combination 3	0.7Ms + (MP + MT)	
8	Load combination 4	Ms + 0.7(MP + Mt)	

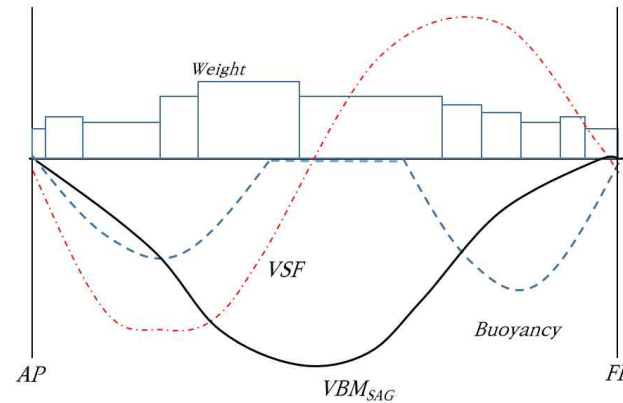
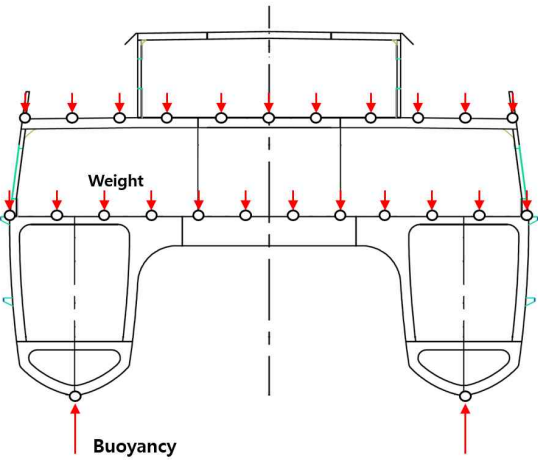
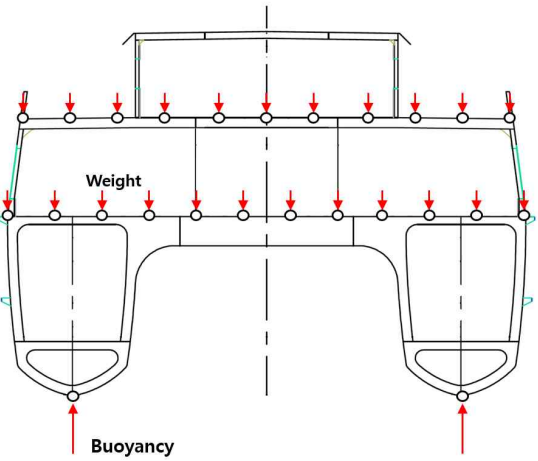
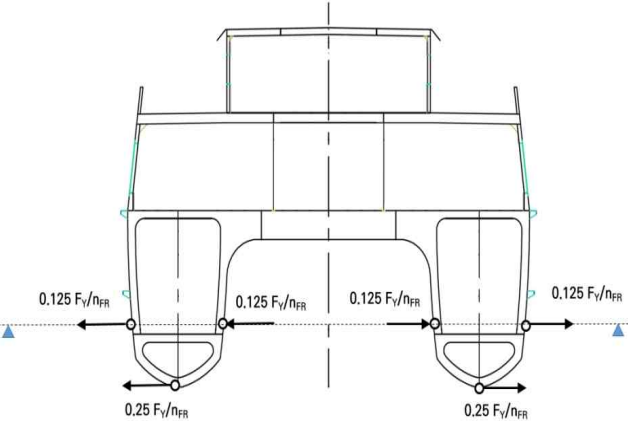
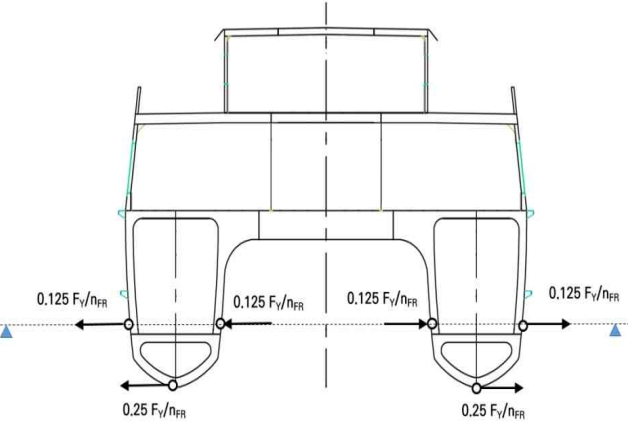
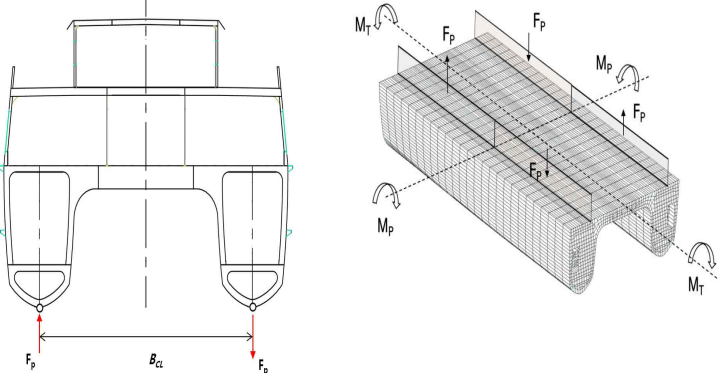
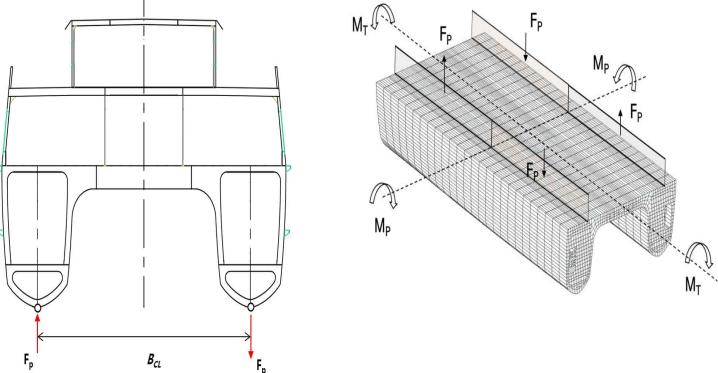

Figure 3.1.2 An example of weight, buoyancy, shear force and bending moment diagram (refer to Figure 3.2.11 of the Rules)

- Typo
:Table 3-6 =>
Table 6

- Typo
:Fig 3.1.2
=>Fig 2

Present	Correction	Reason
 <p data-bbox="280 742 817 790">Figure 3.1.3 An example for application of weight and buoyancy</p>	 <p data-bbox="1176 742 1713 790">Figure 3.1.3 An example for application of weight and buoyancy</p>	<p data-bbox="1892 247 2128 446">- Typo : Fig 3.1.3 => Fig 3 Fig 3.1.4 => Fig 4</p>
 <p data-bbox="280 1348 907 1396">Figure 3.1.4 Application of horizontal split force for transverse bending moment (nFr is no. of frames)</p>	 <p data-bbox="1176 1348 1803 1396">Figure 3.1.4 Application of horizontal split force for transverse bending moment (nFr is no. of frames)</p>	

Present	Correction	Reason
 <p data-bbox="224 694 828 742">Figure 3.1.5 Application of pitch connecting force for longitudinal/transverse torsional moment</p> <p data-bbox="112 845 515 877">Table 3.5 Failure Strength Ratio, R</p> <p data-bbox="918 917 952 949">↓</p>	 <p data-bbox="1120 694 1724 742">Figure 3.1.5 Application of pitch connecting force for longitudinal/transverse torsional moment</p> <p data-bbox="1008 845 1411 877">Table 3.5 Failure Strength Ratio, R</p> <p data-bbox="1814 917 1848 949">↓</p>	<p data-bbox="1892 239 2016 359">-Typo :Fig 3.1.5 =>Fig 5</p> <p data-bbox="1892 798 2083 917">-Typo :Table 3.5 => Table 5</p>

Present	Correction	Reason
<p>Annex 3–2 Guidance for Buckling Strength Calculation</p> <p>1. Buckling Strength Calculation for Steel Ships</p> <p><omit></p> <p>(B) Relationships for buckling strength calculation are as follow.</p> <p>(a) when $\sigma_{el} < \frac{\sigma_f}{2}$: $\sigma_c = \sigma_{el}$, when $\sigma_{el} > \frac{\sigma_f}{2}$:</p> $\sigma_c = \sigma_f \left(1 - \frac{\sigma_f}{4\sigma_{el}} \right)$ <p>(b) when $\tau_{el} < \frac{\tau_f}{2}$: $\tau_c = \tau_{el}$, when $\tau_{el} > \frac{\tau_f}{2}$:</p> $\tau_c = \tau_f \left(1 - \frac{\tau_f}{4\tau_{el}} \right)$ <p>(c) when the required σ_c or τ_c is known, the necessary σ_{el} or τ_{el} will from the above expressions of Johnson–Ostenfeld relationship be:</p> $\sigma_{el} = \frac{\sigma_c}{K_{J-O}} \text{ and } \tau_{el} = \frac{\tau_c}{K_{J-O}}$ <p>K_{J-O} : from Fig 3.1 or from the formula as follow.</p> $K_{J-O} = 1 - \left(\frac{\sigma_c \text{ or } \tau_c}{0.5(\sigma_c \text{ or } \tau_c)} - 1 \right)^2$ <p>For $\frac{\sigma_c}{\sigma_f} < 0.5$, $K_{J-O} = 1$</p>	<p>Annex 3–2 Guidance for Buckling Strength Calculation</p> <p>1. Buckling Strength Calculation for Steel Ships</p> <p><omit></p> <p>(B) Relationships for buckling strength calculation are as follow.</p> <p>(a) when $\sigma_{el} < \frac{\sigma_f}{2}$: $\sigma_c = \sigma_{el}$, when $\sigma_{el} > \frac{\sigma_f}{2}$:</p> $\sigma_c = \sigma_f \left(1 - \frac{\sigma_f}{4\sigma_{el}} \right)$ <p>(b) when $\tau_{el} < \frac{\tau_f}{2}$: $\tau_c = \tau_{el}$, when $\tau_{el} > \frac{\tau_f}{2}$:</p> $\tau_c = \tau_f \left(1 - \frac{\tau_f}{4\tau_{el}} \right)$ <p>(c) when the required σ_c or τ_c is known, the necessary σ_{el} or τ_{el} will from the above expressions of Johnson–Ostenfeld relationship be:</p> $\sigma_{el} = \frac{\sigma_c}{K_{J-O}} \text{ and } \tau_{el} = \frac{\tau_c}{K_{J-O}}$ <p>K_{J-O} : from Fig 3.1 or from the formula as follow.</p> $K_{J-O} = 1 - \left(\frac{\sigma_c \text{ or } \tau_c}{0.5(\sigma_c \text{ or } \tau_c)} - 1 \right)^2$ <p>For $\frac{\sigma_c}{\sigma_f} < 0.5$, $K_{J-O} = 1$</p>	<p>– Typo :Fig 3.1 =>Fig 1</p>

Present	Correction	Reason
<p><omit> (4) Plating (A) Plate panel in uni-axial compression (a) The ideal elastic buckling stress may be taken as:</p> $\sigma_{el} = 0.9 k E \left(\frac{t}{1000s} \right)^2 \quad (\text{N/mm}^2)$ <p>k : coefficient in accordance with Table 3.6 $c = 1.21$ (when stiffeners are angles or T-sections) = 1.10 (when stiffeners are bulb flats) = 1.05 (when stiffeners are flat bars) For double bottom panels the c-values may be multiplied by 1.1 φ : the ratio between the smaller and the larger compression stress assuming linear variation in accordance with Table 3.2</p>	<p><omit> (4) Plating (A) Plate panel in uni-axial compression (a) The ideal elastic buckling stress may be taken as:</p> $\sigma_{el} = 0.9 k E \left(\frac{t}{1000s} \right)^2 \quad (\text{N/mm}^2)$ <p>k : coefficient in accordance with Table 3.6¹ $c = 1.21$ (when stiffeners are angles or T-sections) = 1.10 (when stiffeners are bulb flats) = 1.05 (when stiffeners are flat bars) For double bottom panels the c-values may be multiplied by 1.1 φ : the ratio between the smaller and the larger compression stress assuming linear variation in accordance with TableFig 3.2</p>	<p>-Typo :Table 3.6 => Table 1 Table 3.2 =>Fig 2</p>

Present

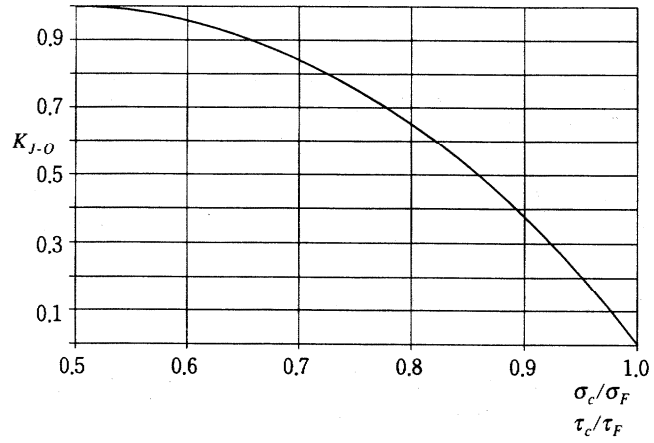

Fig 3.1 Factor K_{J-0}

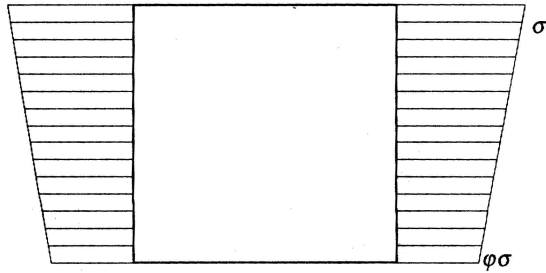

Fig 3.2 Buckling Stress Correction Factor

Correction

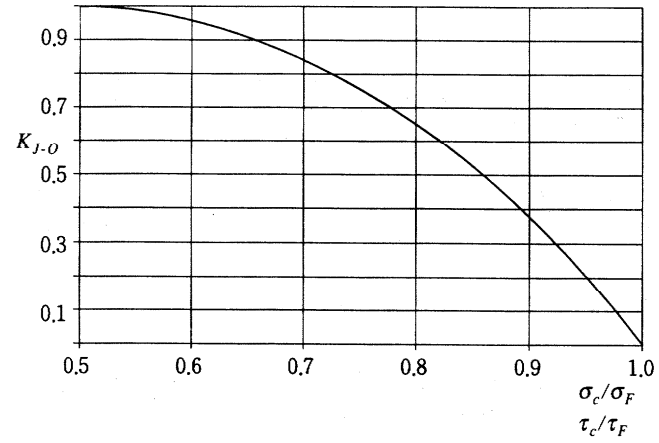

Fig 3.1 Factor K_{J-0}

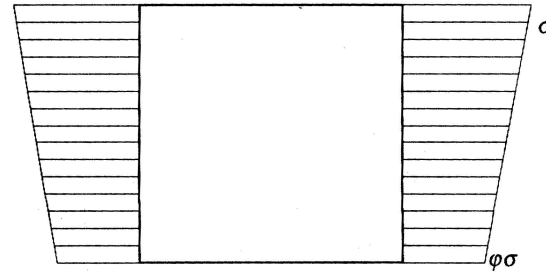

Fig 3.2 Buckling Stress Correction Factor

Reason

- Typo
: Fig 3.1
=> Fig 1
Fig 3.2
=> Fig 2

Present	Correction	Reason
<p>(C) Plate panel in bi-axial compression and shear (a) For plate panels subject to bi-axial compression and in addition to in-plane shear stresses the interaction is given as follows.</p> $\frac{\sigma_{ax}}{\eta_x \sigma_{cx} q} - K \frac{\sigma_{ax} \sigma_{ay}}{\eta_x \eta_y \sigma_{cx} \sigma_{cy} q} + \left(\frac{\sigma_{ay}}{\eta_y \sigma_{cy} q} \right)^n \leq 1$ <p>σ_{ax} : compression stress in longitudinal direction (perpendicular to stiffener spacing s) σ_{ay} : compression stress in transverse direction (perpendicular to the longer side l of the plate panel) σ_{cx} : critical buckling stress in longitudinal direction (perpendicular to stiffener spacing s) σ_{cy} : critical buckling stress in transverse direction (perpendicular to the longer side l of the plate panel) $\eta_x, \eta_y = 1.0$: for plate panels where the longitudinal stress σ_a or other extreme stress is incorporated in and constitutes a major part of σ_{ax} or σ_{ay} = 0.95 η_G in other cases $K = c \beta^a$ c, a, n : factors given in Table 3.7 $\beta = 1000 \frac{s}{t} \sqrt{\frac{\sigma_f}{E}}, \quad q = 1 - \left(\frac{\tau_a}{\eta_t \tau_c} \right)^2$ $\eta_\tau = \eta$: as specified in (B) (b) above</p>	<p>(C) Plate panel in bi-axial compression and shear (a) For plate panels subject to bi-axial compression and in addition to in-plane shear stresses the interaction is given as follows.</p> $\frac{\sigma_{ax}}{\eta_x \sigma_{cx} q} - K \frac{\sigma_{ax} \sigma_{ay}}{\eta_x \eta_y \sigma_{cx} \sigma_{cy} q} + \left(\frac{\sigma_{ay}}{\eta_y \sigma_{cy} q} \right)^n \leq 1$ <p>σ_{ax} : compression stress in longitudinal direction (perpendicular to stiffener spacing s) σ_{ay} : compression stress in transverse direction (perpendicular to the longer side l of the plate panel) σ_{cx} : critical buckling stress in longitudinal direction (perpendicular to stiffener spacing s) σ_{cy} : critical buckling stress in transverse direction (perpendicular to the longer side l of the plate panel) $\eta_x, \eta_y = 1.0$: for plate panels where the longitudinal stress σ_a or other extreme stress is incorporated in and constitutes a major part of σ_{ax} or σ_{ay} = 0.95 η_G in other cases $K = c \beta^a$ c, a, n : factors given in Table 3.72 $\beta = 1000 \frac{s}{t} \sqrt{\frac{\sigma_f}{E}}, \quad q = 1 - \left(\frac{\tau_a}{\eta_t \tau_c} \right)^2$ $\eta_\tau = \eta$: as specified in (B) (b) above</p>	<p>-Typo :Table 3.7 => Table 2</p>

Present	Correction	Reason																								
<p>Table 3.6 Factor (k)</p> <table border="1"> <thead> <tr> <th>structure</th> <th>Factor (k)</th> </tr> </thead> <tbody> <tr> <td>plating with longitudinal stiffeners (in the direction of compression stress)</td> <td>$k = k_l = \frac{8.4}{\varphi + 1.1} \quad (0 \leq \varphi \leq 1)$</td> </tr> <tr> <td>plating with transverse stiffeners (perpendicular to the compression stress)</td> <td>$k = k_s = c \left[1 + \left(\frac{s}{l} \right)^2 \right]^2 \frac{2.1}{\varphi + 1.1} \quad (0 \leq \varphi)$</td> </tr> </tbody> </table>	structure	Factor (k)	plating with longitudinal stiffeners (in the direction of compression stress)	$k = k_l = \frac{8.4}{\varphi + 1.1} \quad (0 \leq \varphi \leq 1)$	plating with transverse stiffeners (perpendicular to the compression stress)	$k = k_s = c \left[1 + \left(\frac{s}{l} \right)^2 \right]^2 \frac{2.1}{\varphi + 1.1} \quad (0 \leq \varphi)$	<p>Table 3.61 Factor (k)</p> <table border="1"> <thead> <tr> <th>structure</th> <th>Factor (k)</th> </tr> </thead> <tbody> <tr> <td>plating with longitudinal stiffeners (in the direction of compression stress)</td> <td>$k = k_l = \frac{8.4}{\varphi + 1.1} \quad (0 \leq \varphi \leq 1)$</td> </tr> <tr> <td>plating with transverse stiffeners (perpendicular to the compression stress)</td> <td>$k = k_s = c \left[1 + \left(\frac{s}{l} \right)^2 \right]^2 \frac{2.1}{\varphi + 1.1} \quad (0 \leq \varphi)$</td> </tr> </tbody> </table>	structure	Factor (k)	plating with longitudinal stiffeners (in the direction of compression stress)	$k = k_l = \frac{8.4}{\varphi + 1.1} \quad (0 \leq \varphi \leq 1)$	plating with transverse stiffeners (perpendicular to the compression stress)	$k = k_s = c \left[1 + \left(\frac{s}{l} \right)^2 \right]^2 \frac{2.1}{\varphi + 1.1} \quad (0 \leq \varphi)$	<p>-Typo :Table 3.6 => Table 1 :Table 3.7 => Table 2</p>												
structure	Factor (k)																									
plating with longitudinal stiffeners (in the direction of compression stress)	$k = k_l = \frac{8.4}{\varphi + 1.1} \quad (0 \leq \varphi \leq 1)$																									
plating with transverse stiffeners (perpendicular to the compression stress)	$k = k_s = c \left[1 + \left(\frac{s}{l} \right)^2 \right]^2 \frac{2.1}{\varphi + 1.1} \quad (0 \leq \varphi)$																									
structure	Factor (k)																									
plating with longitudinal stiffeners (in the direction of compression stress)	$k = k_l = \frac{8.4}{\varphi + 1.1} \quad (0 \leq \varphi \leq 1)$																									
plating with transverse stiffeners (perpendicular to the compression stress)	$k = k_s = c \left[1 + \left(\frac{s}{l} \right)^2 \right]^2 \frac{2.1}{\varphi + 1.1} \quad (0 \leq \varphi)$																									
<p>Table 3.7 Factors a, c and n</p> <table border="1"> <thead> <tr> <th></th> <th>c</th> <th>a</th> <th>n</th> </tr> </thead> <tbody> <tr> <td>$1.0 < l/s \leq 1.5$</td> <td>0.78</td> <td>-0.12</td> <td>1.0</td> </tr> <tr> <td>$1.5 < l/s < 8$</td> <td>0.80</td> <td>0.04</td> <td>1.2</td> </tr> </tbody> </table>		c	a	n	$1.0 < l/s \leq 1.5$	0.78	-0.12	1.0	$1.5 < l/s < 8$	0.80	0.04	1.2	<p>Table 3.72 Factors a, c and n</p> <table border="1"> <thead> <tr> <th></th> <th>c</th> <th>a</th> <th>n</th> </tr> </thead> <tbody> <tr> <td>$1.0 < l/s \leq 1.5$</td> <td>0.78</td> <td>-0.12</td> <td>1.0</td> </tr> <tr> <td>$1.5 < l/s < 8$</td> <td>0.80</td> <td>0.04</td> <td>1.2</td> </tr> </tbody> </table>		c	a	n	$1.0 < l/s \leq 1.5$	0.78	-0.12	1.0	$1.5 < l/s < 8$	0.80	0.04	1.2	
	c	a	n																							
$1.0 < l/s \leq 1.5$	0.78	-0.12	1.0																							
$1.5 < l/s < 8$	0.80	0.04	1.2																							
	c	a	n																							
$1.0 < l/s \leq 1.5$	0.78	-0.12	1.0																							
$1.5 < l/s < 8$	0.80	0.04	1.2																							

Present	Correction	Reason
<p>(6) Stiffeners Perpendicular to Direction of Compression For longitudinal structures, the moment of inertia of the stiffener section is not to be less than the follows.</p> $I = \frac{0.09 \sigma_a \sigma_{el} l^4 s}{t} \quad (\text{cm}^4)$ <p>l : span of stiffener (m) s : spacing of stiffener (m) t : plate thickness (mm)</p> $\sigma_{el} = \frac{\sigma_c}{K_{J-O}}, \quad \sigma_c = \frac{\sigma_a}{0.85}$ <p>σ_a : actual compression stress(N/mm²), for the local load stress, the value of stress divided by η_G specified in (4) (A) (b) above. K_{J-O} : according to Fig 3.1</p>	<p>(6) Stiffeners Perpendicular to Direction of Compression For longitudinal structures, the moment of inertia of the stiffener section is not to be less than the follows.</p> $I = \frac{0.09 \sigma_a \sigma_{el} l^4 s}{t} \quad (\text{cm}^4)$ <p>l : span of stiffener (m) s : spacing of stiffener (m) t : plate thickness (mm)</p> $\sigma_{el} = \frac{\sigma_c}{K_{J-O}}, \quad \sigma_c = \frac{\sigma_a}{0.85}$ <p>σ_a : actual compression stress(N/mm²), for the local load stress, the value of stress divided by η_G specified in (4) (A) (b) above. K_{J-O} : according to Fig 3.1</p>	<p>-Typo :Fig 3.1 =>Fig 1</p>

Present	Correction	Reason
<p>(4) Plating (A) Plate panel in uni-axial compression (a) The ideal elastic buckling stress may be taken as:</p> $\sigma_{el} = 0.9 k E \left(\frac{1}{1000 s} \right)^2 \quad (\text{N/mm}^2)$ <p>k : see Table 3.6 c = 2.50 (when stiffeners are hollow profile with $s/l < 0,5$ and the enclosed area of the hollow profile is larger than 20 st) = 1.21 (when stiffeners are angles or T-sections) = 1.10 (when stiffeners are bulb flats) = 1.05 (when stiffeners are flat bars) For double bottom panels the c-values may be multiplied by 1.1. φ is the ratio between the smaller and the larger compressive stress assuming linear variation, see Fig 3.2.</p>	<p>(4) Plating (A) Plate panel in uni-axial compression (a) The ideal elastic buckling stress may be taken as:</p> $\sigma_{el} = 0.9 k E \left(\frac{1}{1000 s} \right)^2 \quad (\text{N/mm}^2)$ <p>k : see Table 3.61 c = 2.50 (when stiffeners are hollow profile with $s/l < 0,5$ and the enclosed area of the hollow profile is larger than 20 st) = 1.21 (when stiffeners are angles or T-sections) = 1.10 (when stiffeners are bulb flats) = 1.05 (when stiffeners are flat bars) For double bottom panels the c-values may be multiplied by 1.1. φ is the ratio between the smaller and the larger compressive stress assuming linear variation, see Fig 3.2.</p>	<p>-Typo :Table 3.6 => Table 1 :Fig 3.2 =>Fig 2</p>

Present	Correction	Reason
<p>(C) Plate panel in bi-axial compression and shear (a) For plate panels subject to bi-axial compression the interaction between the longitudinal and transverse buckling strength ratios is given by:</p> $\frac{\sigma_{ax}}{\eta_x \sigma_{ax} q} - K \frac{\sigma_{ax} \sigma_{ay}}{\eta_x \eta_y \sigma_{ax} \sigma_{ay} q} + \left(\frac{\sigma_{ay}}{\eta_y \sigma_{ay} q} \right)^n \leq 1$ <p>σ_{ax} : compressive stiffness in longitudinal direction (perpendicular to stiffener spacing s) σ_{ay} : compressive stress in transverse direction (perpendicular to the longer side l of the plate panel) σ_{cx} : critical buckling stress in longitudinal direction (perpendicular to stiffener spacing s) σ_{cy} : critical buckling stress in transverse direction (perpendicular to the longer side l of the plate panel) $\eta_x, \eta_y = 1.0$: for plate panels where the longitudinal stress σ_a or other extreme stress is incorporated and constitutes a major part in σ_{ax} or σ_{ay} = $0.95 \eta_G$: other cases $K = c \beta^a$ c, a, n : see Table 3.7</p>	<p>(C) Plate panel in bi-axial compression and shear (a) For plate panels subject to bi-axial compression the interaction between the longitudinal and transverse buckling strength ratios is given by:</p> $\frac{\sigma_{ax}}{\eta_x \sigma_{ax} q} - K \frac{\sigma_{ax} \sigma_{ay}}{\eta_x \eta_y \sigma_{ax} \sigma_{ay} q} + \left(\frac{\sigma_{ay}}{\eta_y \sigma_{ay} q} \right)^n \leq 1$ <p>σ_{ax} : compressive stiffness in longitudinal direction (perpendicular to stiffener spacing s) σ_{ay} : compressive stress in transverse direction (perpendicular to the longer side l of the plate panel) σ_{cx} : critical buckling stress in longitudinal direction (perpendicular to stiffener spacing s) σ_{cy} : critical buckling stress in transverse direction (perpendicular to the longer side l of the plate panel) $\eta_x, \eta_y = 1.0$: for plate panels where the longitudinal stress σ_a or other extreme stress is incorporated and constitutes a major part in σ_{ax} or σ_{ay} = $0.95 \eta_G$: other cases $K = c \beta^a$ c, a, n : see Table 3.72</p>	<p>- Typo :Table 3.7 => Table 2</p>

Present	Correction	Reason
<p>(6) Stiffeners perpendicular to direction of compression For stiffeners supporting plating subject to compression stresses perpendicular to the stiffener direction the moment of inertia of the stiffener section (including effective plate flange) is not to be less than:</p> $I = \frac{0.81 \sigma_a \sigma_{el} l^4 s}{t} \quad (\text{cm}^4)$ <p>l : span of stiffener (m) s : spacing of stiffener (m) t : plate thickness (mm)</p> $\sigma_{el} = \frac{\sigma_c}{K_{J-O}}$ $\sigma_c = \frac{\sigma_a}{0.85}$ <p>σ_a : calculated extreme compressive stress, or ordinary local load stress divided by η_G K_{J-O} : Fig 3.1</p> <p style="text-align: right;">↓</p>	<p>(6) Stiffeners perpendicular to direction of compression For stiffeners supporting plating subject to compression stresses perpendicular to the stiffener direction the moment of inertia of the stiffener section (including effective plate flange) is not to be less than:</p> $I = \frac{0.81 \sigma_a \sigma_{el} l^4 s}{t} \quad (\text{cm}^4)$ <p>l : span of stiffener (m) s : spacing of stiffener (m) t : plate thickness (mm)</p> $\sigma_{el} = \frac{\sigma_c}{K_{J-O}}$ $\sigma_c = \frac{\sigma_a}{0.85}$ <p>σ_a : calculated extreme compressive stress, or ordinary local load stress divided by η_G K_{J-O} : Fig 3.1</p> <p style="text-align: right;">↓</p>	<p>-Typo :Fig 3.1 =>Fig 1</p>

Present	Amendment	Note
<p data-bbox="241 261 987 300"><Guidance for Floating Production Units></p> <p data-bbox="389 352 837 391">CHAPTER 1 GENERAL</p> <p data-bbox="477 454 748 493">Section 1 General</p> <p data-bbox="226 528 557 555">102. Classification of units</p> <p data-bbox="248 568 479 595">1. Purpose of units</p> <p data-bbox="271 619 754 646">(3) FSO (Floating Production and Storage)</p> <p data-bbox="324 659 999 727">FSO is a unit with systems for the storage and off-loading of produced crude oil and petroleum gases.</p>	<p data-bbox="1059 255 1805 293"><Guidance for Floating Production Units></p> <p data-bbox="1207 346 1655 384">CHAPTER 1 GENERAL</p> <p data-bbox="1294 448 1565 486">Section 1 General</p> <p data-bbox="1028 521 1359 549">102. Classification of units</p> <p data-bbox="1050 561 1281 588">1. Purpose of units</p> <p data-bbox="1075 612 1559 639">(3) FSO (Floating Storage and Offloading)</p> <p data-bbox="1128 652 1834 721">FSO is a unit with systems for the storage and offloading of produced crude oil and petroleum gases.</p>	<p data-bbox="1861 560 2107 628">– Edited for translation error.</p>